



Inspiring Great Spaces®



2019

BUILDER
PROPERTY MANAGEMENT
MULTIFAMILY

YOUR PARTNER IN FLOORING

Let the Buyer Have Faith

Armstrong Flooring, Inc. is the trusted, global leader in the design and manufacture of flooring solutions. We create innovative flooring solutions that inspire spaces where people live, work, learn, heal, and play. We are a company of amazing people working together to provide the highest level of service and quality to ensure that our company is as strong and vital as our heritage. Every day, our actions embody Thomas Armstrong's founding motto: "Let the buyer have faith."

Our Diamond Standard of Quality affirms our century-long commitment to being the most trusted flooring resource known for superior service and support, uncompromising quality, and persistent innovation. From developing visuals and color palettes that inspire fresh, exciting designs, to providing rigorously tested, high-performance flooring solutions for optimum durability, our Diamond Standard of Quality is evident in everything we do — and it's why people confidently choose, specify, and trust Armstrong Flooring products again and again.



VIVERO® GOOD
 Charlestown Oak
 Mocha U5041/U6041

TABLE OF CONTENTS

The Armstrong Flooring Advantage 2-5

- Environmentally Sustainable

PRODUCTS

Rigid Core Flooring 6-15

- Pryzm™
- Rigid Core Vantage™ & Rigid Core Vantage™ R
- Luxe Plank® with Rigid Core
- Rigid Core Elements™

Luxury Flooring/LVT 16-30

- Luxe Plank® with FasTak™
- Luxe Plank® with Lynx® Technology
- Parallel® 12/20
- Natural Personality™ 2
- American Personality™ 12
- Vivero® Good

Acoustics Data 31

Vinyl Tile 32-33

- Caliber™
- Afton™ Series, Units™

Engineered Tile 34-43

- Alterna®
- Alterna on the Walls
- Alterna Accessories

Vinyl Sheet 44-64

- StrataMax® Good, Value Plus, Value
- FlexStep™ Good, Value Plus
- Station Square™
- Initiator™

Underlayment Options 65

Recommended Adhesives 66

Care and Maintenance 66



RIGID CORE VANTAGE™
Camargo Oak
Nickel Mine A6913

CATERED TO YOUR INDUSTRY

Armstrong Flooring understands the unique set of challenges that builders and property managers face when choosing flooring for their homes and communities. We recognize the importance of quick turnaround times, product availability and dependability. That's why we guarantee an impressive array of readily available, stylish, durable and easy-to-install options at every price point.

BRAND LEADER
Builder
2017

Armstrong Flooring has over 150 years of experience, quality and innovation in hard surface flooring. To meet the unique needs of our builder and property management customers, we provide:

- Superb quality and realistic designs from trusted brands that are desirable to your home buyers and residents
- Reliable availability through Recommended Style Lists (RSL) in every category which ensure the products listed will be available all year
- Innovative product technology that allows for quick and easy repairs and better damage control
- Large selection of products across categories for every price point and every budget

This catalog represents only a portion of the Armstrong Flooring product portfolio. Please contact your local sales representative or go to www.armstrongflooring.com for additional product selections.

*Hanley Wood Brand Leader Study 2017

ENVIRONMENTALLY SUSTAINABLE

SUSTAINABILITY AND COMMUNITY INVOLVEMENT

Armstrong Flooring has a proud, long history of sustainability and environmental stewardship and we believe one of the reasons we have stood the test of time is our commitment to acting responsibly and with integrity everywhere we work. Armstrong Flooring has twelve (12) manufacturing facilities in the United States and our Corporate Headquarters was the first building in Pennsylvania to receive Platinum LEED certification. For more information about sustainability commitments and our community contributions, go to www.armstrongflooring.com/corporate/en-us/sustainability.html.

Luxury Flooring, Vinyl Tile and Vinyl Sheet

Armstrong® vinyl sheet, vinyl tile and LVT are FloorScore® certified and ortho-phthalate free. Products with FloorScore certification are guaranteed to meet or exceed low emission standards, will not adversely affect indoor air quality and have passed a third party certification process.

Engineered Tile

Alterna® Engineered Tile is FloorScore certified, ortho-phthalate free and contains a minimum of 40% pre-consumer recycled content.

2018 Green Builder Magazine Award



Armstrong recycles LVT and VCT.
Visit www.armstrongflooring.com/reclaim



Exclusive Flooring Partner

*This product is recyclable through the Armstrong Floor Recycling Program and may be subject to limitations based on site conditions and minimum quantity requirements. To learn more visit: www.armstrongflooring.com/reclaim.



FloorScore is a trademark of the Resilient Floor Covering Institute. LEED is a trademark owned by the United States Green Building Council.

PRYZM™

RIGID CORE FLOORING

- 100% waterproof* planks, ideal for high moisture areas including kitchens, bathrooms and basements
- Innovative reinforced thermoplastic core enables a smooth transition over subfloor irregularities
- Award winning MasterWorks Technology® creates the clearest images, most vibrant colors and most realistic designs
- Commercial VisionGuard® with AC4 wear layer protects against scratches, spills, dents, stains, fading and wear-through
- No acclimation required before installation
- Spans larger areas before needing a transition strip for a faster, more beautiful installation**
- Ultimate dent resistance - withstands the heavy weight of appliances and furniture, and daily impact from kids' cleats to high heels



PRYZM™
Elements of Heritage
Vintage Multi PC020

PRODUCT STRUCTURE PRYZM RIGID CORE FLOORING

- AC4 Commercial Wear Layer
- Printed Décor Design Layer
- Thermoplastic Composite
Waterproof* Core
- Cork Backing Acoustic Pad

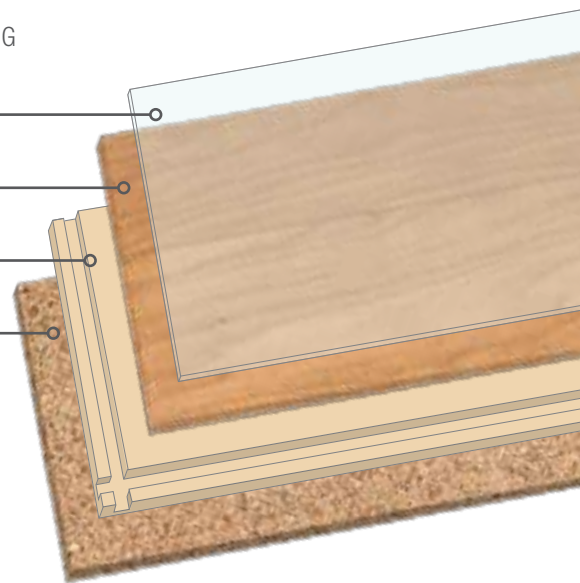

*When exposed to water PRYZM planks will not swell, buckle or lose integrity. See warranty for details.

**T-moldings must be used between rooms or in areas larger than 80' (24.38 m) across plank length or wider than 52' (15.85 m) across plank width.

SPECIFICATIONS

OVERALL THICKNESS
6.5" mm thick

WEAR LAYER
AC4

BACKING
Acoustical cork

INSTALLATION
Locking

LIMITED WARRANTY
Res: Lifetime Limited
Com: 15-year Limited

PLANK SIZE
4.3"/5.6"/7" X 47.56"
5" X 47.56"
5.7" X 47.56"
6.6" X 47.56"

PIECES PER CARTON
4.3"/5.6"/7" - 3/6/3 pcs
5" - 12 pcs
5.7" - 12 pcs
6.6" - 10 pcs

SQ. FT. PER CARTON
4.3"/5.6"/7" - 22.47 sq ft
5" - 19.97 sq ft
5.7" - 22.63 sq ft
6.6" - 21.71 sq ft



ELEMENTS OF HERITAGE
Vintage Multi PC020
4.3", 5.6" & 7" width planks



ANTIQUED OAK
Natural PC003
5" width planks



MARITIME
Weathered Gray PC007
5" width planks



EXOTIC WOODGRAIN
Reclaimed Gray PC009
5" width planks



AZURE SEA
Blue Gray PC011
5" width planks



WATERFRONT
Pier Brown PC013
5" width planks



TREELINE HICKORY
Amber PC006
5" width planks



WATERFRONT
Sky Blue PC012
5" width planks



COASTAL CONCRETE
Seascapes Gray PC010
5" width planks



NATIVE ACACIA
Golden PC005
5.7" width planks



FOREST TREASURE
White PC017
5.7" width planks



FOREST TREASURE
Brown PC019
5.7" width planks



FOREST TREASURE
Gray PC018
5.7" width planks



VINTAGE CHESTNUT
Antique Natural PC002
5.7" width planks



ARTISAN FLOORBOARD
Light Brown PC004
5.7" width planks



SALVAGED PLANK
White PC001
6.6" width planks



GRAY'S BEACH
Driftwood PC008
6.6" width planks



BRUSHED OAK
Brown PC015
6.6" width planks



BRUSHED OAK
Tan PC014
6.6" width planks



BRUSHED OAK
Gray PC016
6.6" width planks

RIGID CORE VANTAGE™

RIGID CORE FLOORING

- 100% waterproof* planks ideal for high moisture areas and 3-season rooms
- Large format planks with enhanced 4-sided painted bevels to accentuate each plank
- Rigid Core Vantage™ R features the realism of embossed-in-register texture for the look and feel of authentic wood
- Commercial-specification 20 mil wear layer with urethane coating
- Ultimate dent resistance with dense solid polymer composite core
- Premium natural cork pad for reduced sound transmission & hides subfloor irregularities
- Quick & easy one piece drop-lock installation



RIGID CORE VANTAGE™ R
Woodward Winds
Gusty Gray A6921

PRODUCT STRUCTURE

RIGID CORE VANTAGE™ FLOORING

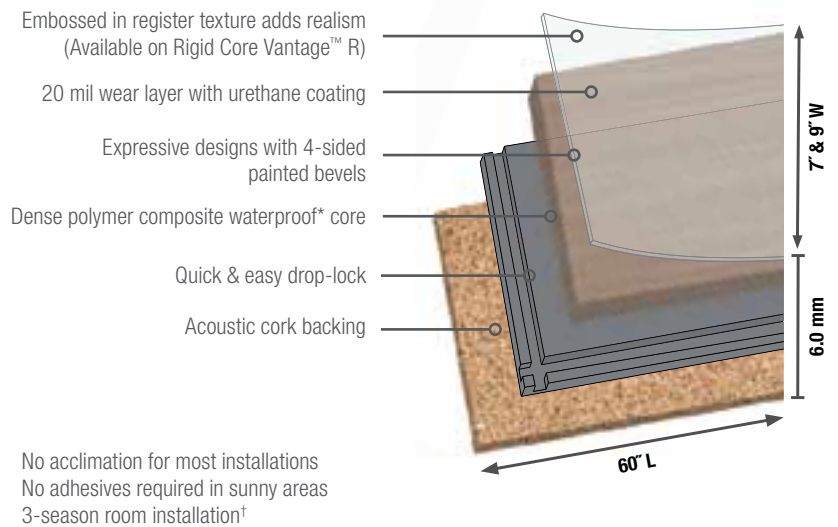

*When exposed to water planks will not swell, buckle or lose integrity. See warranty for details.
†Can be installed in fully-enclosed three-season rooms where the expected temperature range is 32° F to 100° F.

RIGID CORE VANTAGE™ R | SUMMERFIELD OAK



SAND CASTLE
A6904
7" x 60" planks



SUNSET GLOW
A6905
7" x 60" planks



STONE HARBOR GRAY
A6906
7" x 60" planks



DOCKSIDE BROWN
A6903
7" x 60" planks

RIGID CORE VANTAGE™ R | CAMARGO OAK



SILVER DOLLAR
A6910
7" x 60" planks



SAND DOLLAR
A6911
7" x 60" planks



NICKEL MINE
A6913
7" x 60" planks



PENNY ARCADE
A6912
7" x 60" planks

RIGID CORE VANTAGE™ R | WOODWARD WINDS



BEIGE BREEZE
A6920
7" x 60" planks



GUSTY GRAY
A6921
7" x 60" planks



PAINT BRUSH
A6950
7" x 60" planks

RIGID CORE VANTAGE™ | BONANZA SPRINGS

RIGID CORE VANTAGE™ | HICKORY BRIDGE



SALTY
A6930
7" x 60" planks



TENACIOUS TAUPE
A6932
7" x 60" planks



STAYING NEUTRAL
A6931
7" x 60" planks

RIGID CORE VANTAGE™ | SASSAFRAS LODGE



TOASTED MARSHMALLOW
A6960
9" x 60" planks



FALL FOLIAGE
A6961
9" x 60" planks

RIGID CORE VANTAGE™ | CLOVER DALE OAK



GRAY GLIMMER
A6940
7" x 60" planks



SUNNY BLUSH
A6941
7" x 60" planks

RIGID CORE VANTAGE™ | ARTIST LOFT



GRAPHITE
A6980
9" x 60" planks

RIGID CORE VANTAGE™ | FIRESIDE TAVERN



GOLDEN ALE
A6970
9" x 60" planks

SPECIFICATIONS

OVERALL THICKNESS
6 mm thick

WEAR LAYER
UV Coating
20 mil (0.5 mm)

BACKING
Acoustical cork

INSTALLATION
Locking

LIMITED WARRANTY
Res: 30-year Limited
Com: 15-year Limited

PLANK SIZE
7" x 60"
9" x 60"

PIECES PER CARTON
7" x 60" -
6 (17.5 sq. ft.) 1.62 m²
9" x 60" -
6 (22.1 sq. ft.) 2.05 m²

SQ. FT. PER CARTON
6" - 26.32 sq ft
7" - 25.28 sq ft

LUXE PLANK®

WITH RIGID CORE LUXURY FLOORING

RIGID CORE TECHNOLOGY

- 100% waterproof* planks – it's the perfect solution for kitchens, bathrooms, basements and laundry rooms
- Easy to clean & long-lasting – floor resists scratches, stains and wear, making clean up easy
- Durable – thick, rigid composite core hides subfloor irregularities and can span large areas without expansion strips
- Dimensionally stable – no acclimation for most installations



PRODUCT STRUCTURE

LUXE PLANK® BETTER WITH RIGID CORE TECHNOLOGY

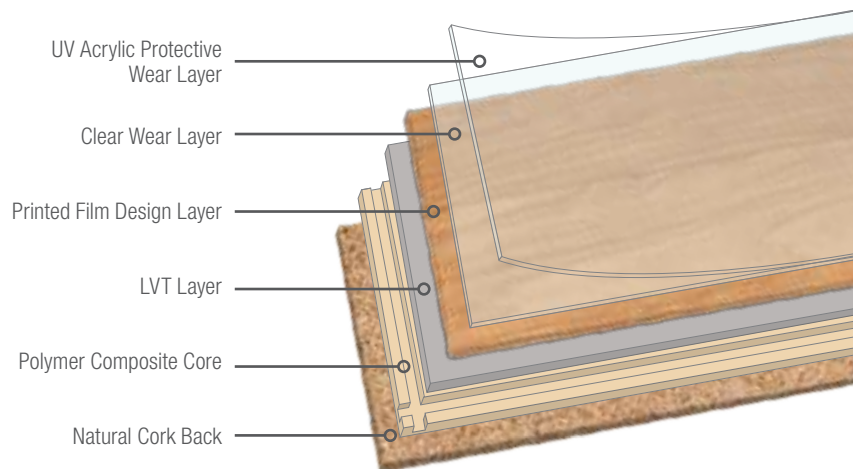

*When exposed to water planks will not swell, buckle or lose integrity. See warranty for details.



LEXINGTON SLATE
Sahara Beige
12" x 24" – A6402



PIAZZA TRAVERTINE
Dovetail
12" x 24" – A6403



LIMED OAK
Chateau Gray
7.2" x 48" – A6414



FARMHOUSE PLANK
Rugged Brown
7.2" x 48" – A6415



FARMHOUSE PLANK
Natural
7.2" x 48" – A6417



GROVELAND
Natural
6" x 48" – A6409



CONCRETE STRUCTURES
Gotham City
6" x 48" – A6421



CONCRETE STRUCTURES
Soho Gray
6" x 48" – A6422



EMPIRE WALNUT
Flint Gray
6" x 48" – A6411



EMPIRE WALNUT
Raven
6" x 48" – A6420



PRIMITIVE FOREST
Falcon
6" x 48" – A6423



TIOGA TIMBER
Java
6" x 48" – A6410



TROPICAL OAK
Natural
6" x 48" – A6412



COUNTRYSIDE OAK
Gunstock
6" x 48" – A6413



ACACIA
Cinnabar
6" x 48" – A6408



ACACIA
Natural
6" x 48" – A6407

SPECIFICATIONS

OVERALL THICKNESS
8 mm

WEAR LAYER
20 mil

INSTALLATION
Locking

LIMITED WARRANTY
Res: 30-year Limited
Com: 10-year Limited

PLANK SIZE
12" X 24"
6" X 48"
7.2" X 48"

PIECES PER CARTON
12" - 14 pcs
6" - 14 pcs
7" - 14 pcs

SQ. FT. PER CARTON
12" - 28.03 sq ft
6" - 27.39 sq ft
7" - 28.5 sq ft



KEYSTONE OAK
White Veil
7.2' x 48" – A6438



TRAVERTINE
Misty Day
12" x 24" – A6445



TRAVERTINE
Natural Linen
12" x 24" – A6446



CASTLETOWN
Silver Mine
7.2' x 48" – A6453



CASTLETOWN
Sweet Caramel
7.2' x 48" – A6454



CASTLETOWN
Carbonized Gray
7.2' x 48" – A6455

SPECIFICATIONS

OVERALL THICKNESS
8 mm

WEAR LAYER
20 mil

INSTALLATION
Locking

LIMITED WARRANTY
Res: 30-year Limited
Com: 10-year Limited

PLANK SIZE
12" X 24"
6" X 48"
7.2" X 48"

PIECES PER CARTON
12" - 14 pcs
6" - 14 pcs
7" - 14 pcs

SQ. FT. PER CARTON
12" - 28.03 sq ft
6" - 27.39 sq ft
7" - 28.5 sq ft



LUXE PLANK® with Rigid Core
Travertine
Natural Linen A6446

RIGID CORE ELEMENTS™

RIGID CORE FLOORING

- 100% waterproof* planks are ideal for high-moisture areas including: kitchens, bathrooms, mudrooms and basements
- Urethane wear layer protects against scratches, scuffs and stains for a long-lasting new floor look and performance
- Dense polymer core provides superior indent resistance and does not telegraph
- Attached polyethylene underlayment helps hide minor subfloor imperfections
- Can be installed over most existing subfloors, OSB or existing flooring
- Reduced sound transmission from attached underlayment



PRODUCT STRUCTURE RIGID CORE ELEMENTS RIGID CORE FLOORING

Protective Coating and Vinyl
Wear Layer

Printed Film Design Layer

Dense Polymer Composite
Waterproof* Core

Polyethylene Acoustic Pad

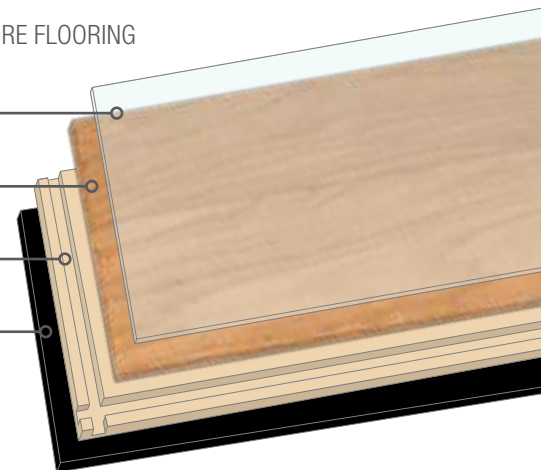

*When exposed to water planks will not swell, buckle or lose integrity. See warranty for details.



AMERICAN ELM
Butternut A6301
6" x 48" planks



AMERICAN ELM
Autumn Landscape A6302
6" x 48" planks



AMERICAN ELM
Bearskin Brown A6303
6" x 48" planks



AMERICAN ELM
Peppercorn A6304
6" x 48" planks



UNIONTOWN OAK
Neutral Sky A6305
6" x 48" planks



UNIONTOWN OAK
Indigo Dust A6306
6" x 48" planks



UNIONTOWN OAK
Roasted Chestnut A6307
6" x 48" planks



DEVON OAK
Burnt Umber A6311
6" x 48" planks



SMITHVILLE OAK
Mocha Taste A6312
6" x 48" planks



SMITHVILLE OAK
Copper Lustre A6313
6" x 48" planks



SMITHVILLE OAK
Warm Embers A6314
6" x 48" planks



SOCIETY OAK
Neutral Ground A6315
6" x 48" planks



HONEYCREEK HICKORY
Early Morning Haze A6310
6" x 48" planks



TAMARRON TIMBER
Gilded Earth A6308
7" x 48" planks

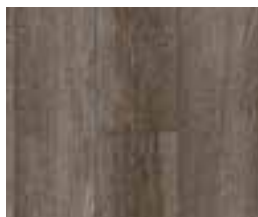

TAMARRON TIMBER
Taupe Terrain A6309
7" x 48" planks

SPECIFICATIONS

OVERALL THICKNESS
5 mm thick

WEAR LAYER
12 mil

BACKING
Acoustical foam

INSTALLATION
Locking

LIMITED WARRANTY
Res: 30-year Limited
Com: 7-year Limited

PLANK SIZE
6" X 48"
7" X 48"

PIECES PER CARTON
6" - 14 pcs
7" - 11 pcs

SQ. FT. PER CARTON
6" - 26.32 sq ft
7" - 25.28 sq ft

LUXE PLANK®

BETTER LUXURY FLOORING

FASTAK™ INSTALLATION

- 100% waterproof planks* - ideal for high-moisture areas including: kitchens, bathrooms and basements
- Sturdy reinforced planks/tiles backed with an innovative pressure-sensitive adhesive to create a beautiful and long-lasting floor
- Reinforced construction provides dimensional stability to resist gapping
- No glue, no pads, no special tools needed
- Easily repositioned during installation – then tightly bonds to the subfloor
- Installs smoothly over most existing subfloors, including those with imperfections
- Repairs easily – individual planks/tiles can be quickly replaced without affecting the rest of the floor



LUXE PLANK® with FasTak™
Acacia
Cinnabar A6708

PRODUCT STRUCTURE

LUXE PLANK® BETTER WITH FASTAK INSTALLATION

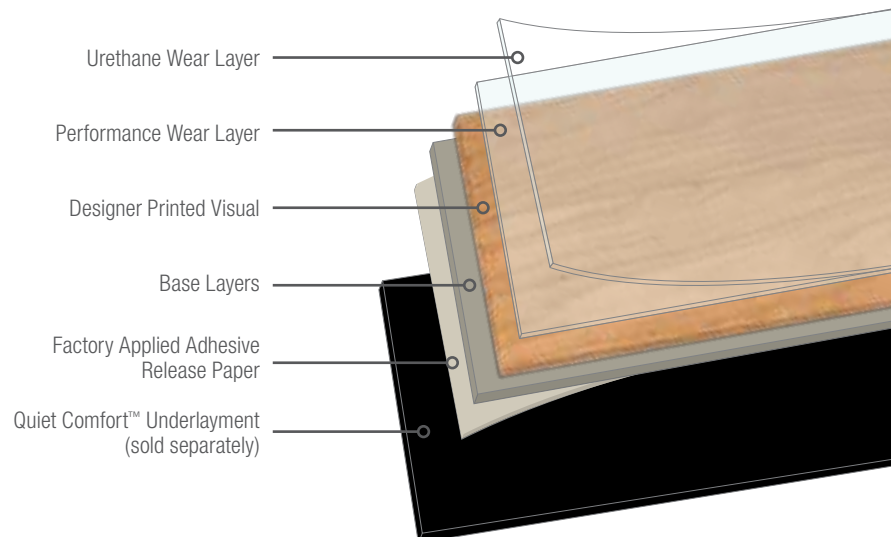

*When exposed to water Luxe planks will not swell, buckle or lose integrity. See warranty for details.



LXINGTON SLATE
Sahara Beige
12" x 24" – A6702



PIAZZA TRAVERTINE
Dovetail
12" x 24" – A6703



LIMED OAK
Chateau Gray
7.2" x 48" – A6714



FARMHOUSE PLANK
Rugged Brown
7.2" x 48" – A6715



FARMHOUSE PLANK
Natural
7.2" x 48" – A6717



GROVELAND
Natural
6" x 48" – A6709



CONCRETE STRUCTURES
Gotham City
6" x 48" – A6721



CONCRETE STRUCTURES
Soho Gray
6" x 48" – A6722



EMPIRE WALNUT
Flint Gray
6" x 48" – A6711



EMPIRE WALNUT
Raven
6" x 48" – A6720



PRIMITIVE FOREST
Falcon
6" x 48" – A6723



TIOGA TIMBER
Java
6" x 48" – A6710



TROPICAL OAK
Natural
6" x 48" – A6712



COUNTRYSIDE OAK
Gunstock
6" x 48" – A6713



ACACIA
Cinnabar
6" x 48" – A6708



ACACIA
Natural
6" x 48" – A6707

SPECIFICATIONS

OVERALL THICKNESS
4.1 mm

WEAR LAYER
12 mil

INSTALLATION
Self-adhering

LIMITED WARRANTY
Res: 30-year Limited
Com: 10-year Limited

PLANK SIZE
12" X 24"
6" X 48"
7.2" X 48"

PIECES PER CARTON
12" - 12 pcs
6" - 12 pcs
7" - 10 pcs

SQ. FT. PER CARTON
12" - 24 sq ft
6" - 24 sq ft
7" - 24.3 sq ft



KEYSTONE OAK
White Veil
7.2' x 48" – A6738



TRAVERTINE
Misty Day
12" x 24" – A6745



TRAVERTINE
Natural Linen
12" x 24" – A6746



CASTLETOWN
Silver Mine
7.2' x 48" – A6753



CASTLETOWN
Sweet Caramel
7.2' x 48" – A6754



CASTLETOWN
Carbonized Gray
7.2' x 48" – A6755

SPECIFICATIONS

OVERALL THICKNESS	4.1 mm
WEAR LAYER	12 mil
INSTALLATION	Self-adhering
LIMITED WARRANTY	Res: 30-year Limited Com: 10-year Limited
PLANK SIZE	12" X 24" 6" X 48" 7.2" X 48"
PIECES PER CARTON	12' - 12 pcs 6" - 12 pcs 7" - 10 pcs
SQ. FT. PER CARTON	12' - 24 sq ft 6" - 24 sq ft 7" - 24.3 sq ft



LUXE PLANK® with FasTak™
Concrete Structures
Soho Gray A6722

LUXE PLANK®

GOOD & VALUE
LUXURY FLOORING

LYNX® TECHNOLOGY INSTALLATION

- Reliable and thick 2.79 mm gauge
- GOOD offers true-to-life hardwood visuals in traditional pine, maple and oak styles
- VALUE offers remarkably realistic hardwood visuals and innovative tile designs that feature grout lines to simulate the look of stone or ceramic
- Urethane coating offers superior performance and resists water and wear
- Lynx Technology – Pressure Sensitive Adhesive requires no glue and no special tools



PRODUCT STRUCTURE

LUXE PLANK® GOOD & VALUE LUXURY FLOORING

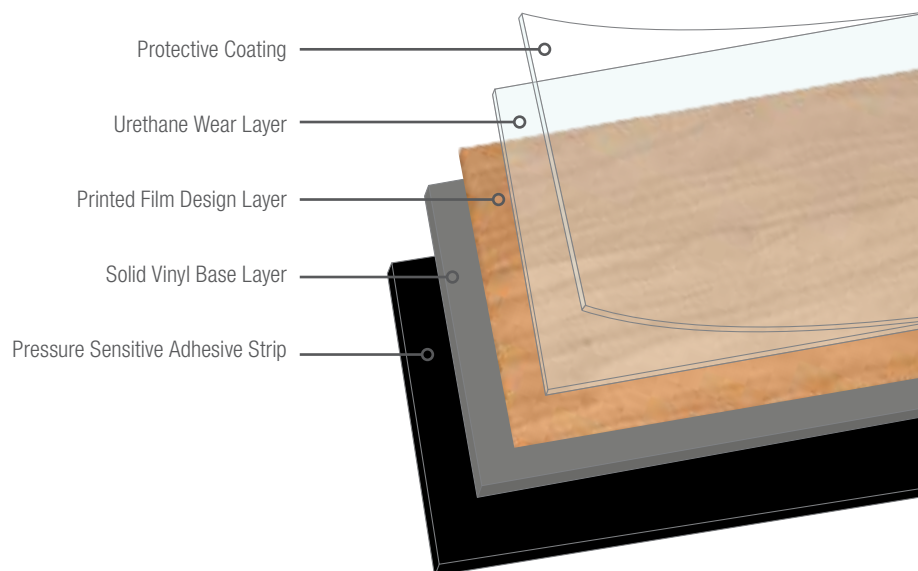

GOOD



JEFFERSON OAK
Golden A6800
6" x 36" planks



JEFFERSON OAK
Gunstock A6801
6" x 36" planks



JEFFERSON OAK
Saddle A6803
6" x 36" planks



PONDEROSA PINE
Natural A6806
6" x 36" planks



SUGAR CREEK MAPLE
Natural A6805
6" x 36" planks



SEASCAPE PLANK
Driftwood A6821
6" x 36" planks

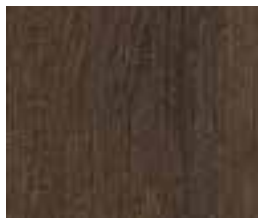

SAWMARK OAK
Chocolate A6822
6" x 36" planks

SPECIFICATIONS

OVERALL THICKNESS
2.79 mm

WEAR LAYER
12 mil

INSTALLATION
Floating

LIMITED WARRANTY
Res: 15-year Limited
Com: 7-year Limited

PLANK SIZE
6" X 36"

PIECES PER CARTON
24 pcs

SQ. FT. PER CARTON
36 sq ft

VALUE



SAPELLI
Spice A6780
6" x 36" planks



BREEZEWOOD
Natural A6781
6" x 36" planks



WOODFIELD
Cinnamon A6782
6" x 36" planks



HICKORY
Caramel Corn A6785
6" x 36" planks



WALNUT GLEN
Tea Chest A6784
6" x 36" planks



MIDWAY
Patina A6795
6" x 36" planks



NEWBRIDGE
Foundry Gray A6786
6" x 36" planks



TALLADEGA TIMBER
Buckthorn Brown A6796
6" x 36" planks

SPECIFICATIONS

OVERALL THICKNESS
2.79 mm

WEAR LAYER
6 mil

INSTALLATION
Floating

LIMITED WARRANTY
Res: 10-year Limited
Com: 5-year Limited

PLANK SIZE
6" X 36"
12" X 36"

PIECES PER CARTON
6" - 24 pcs
12" - 12 pcs

SQ. FT. PER CARTON
6" - 36 sq ft
12" - 36 sq ft



ROCK HILL
Honey Blush A6787
12" x 36" planks



ROCK HILL
Bombay Beige A6788
12" x 36" planks

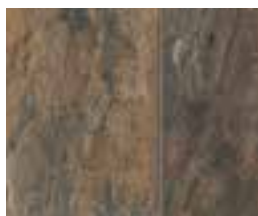

ROCK HILL
Inkwell A6789
12" x 36" planks

PARALLEL® 12/20

BETTER LUXURY FLOORING

- PARALLEL 20 with a 20 mil wear layer addresses the needs of areas with high foot traffic and heavier rolling or static loads
- PARALLEL 12 with a 12 mil wear layer addresses the needs of areas with less foot traffic and lighter rolling or static loads
- High-performance coating resists scratches, scuffs, stains, and damage from alcohol-based hand sanitizers
- Specialized printing techniques and proprietary embossing methods bring textural realism to every design
- Offers minimal resistance to moving objects, making it easy to push, pull, and roll heavy equipment and furniture
- Easy maintenance – helps reduce cleaning time and disruptions



PARALLEL® 12/20
La Crescenta J6126/J6226

PRODUCT STRUCTURE

PARALLEL 12/20 BETTER LUXURY FLOORING

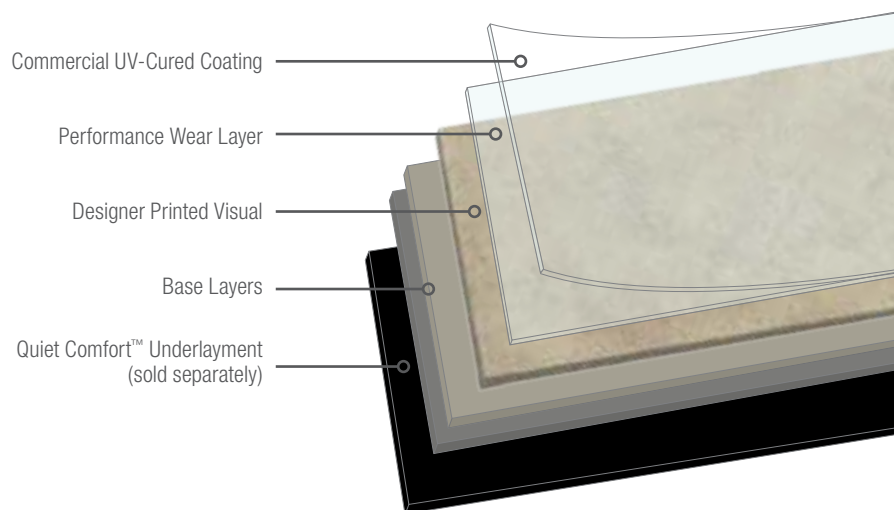



Pacific Coast Highway
12" x 24" – J6122 12 mil
12" x 24" – J6222 20 mil



Mulholland Drive
12" x 24" – J6118 12 mil
12" x 24" – J6218 20 mil



La Jolla Shore
12" x 24" – J6116 12 mil
12" x 24" – J6216 20 mil



Catalina Sand
12" x 24" – J6117 12 mil
12" x 24" – J6217 20 mil

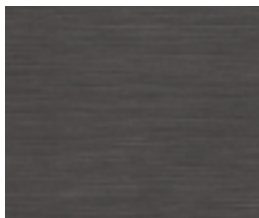

Redondo Beach
12" x 24" – J6119 12 mil
12" x 24" – J6219 20 mil



Silver Sur
6" x 48" – J6129 12 mil
6" x 48" – J6229 20 mil



Huntington Pier
6" x 48" – J6124 12 mil
6" x 48" – J6224 20 mil



Yosemite Bear
6" x 48" – J6127 12 mil
6" x 48" – J6227 20 mil



Trunk of Tahoe
6" x 48" – J6125 12 mil
6" x 48" – J6225 20 mil



Rose Parade
6" x 48" – J6123 12 mil
6" x 48" – J6223 20 mil



Patina LA
6" x 48" – J6104 12 mil
6" x 48" – J6204 20 mil



Los Angelimed
6" x 48" – J6130 12 mil
6" x 48" – J6230 20 mil



Argent CRV
6" x 48" – J6103 12 mil
6" x 48" – J6203 20 mil



Mill Valley
6" x 48" – J6102 12 mil
6" x 48" – J6202 20 mil



La Crescenta
6" x 48" – J6126 12 mil
6" x 48" – J6226 20 mil



Gold Rush
6" x 48" – J6128 12 mil
6" x 48" – J6228 20 mil

SPECIFICATIONS

OVERALL THICKNESS
12 mil - 2 mm
20 mil - 2.5 mm

WEAR LAYER
12 mil
20 mil

INSTALLATION
Glue Down

LIMITED WARRANTY
12 mil
Res: 15-year Limited
Com: 7-year Limited
20 mil
Res: 30-year Limited
Com: 15-year Limited

PLANK SIZE
6" X 48"
12" X 24"

PIECES PER CARTON
6" - 18 pcs
12" - 18 pcs

SQ. FT. PER CARTON
6" - 36 sq ft
12" - 36 sq ft

NATURAL PERSONALITY™ 2

GOOD LUXURY FLOORING

- Hardwood visuals capture the graining and tones of popular wood species: oak, walnut, hickory and pine
- Guaranteed not to rip, tear or gouge from normal household use, multiple tenants and moves
- Urethane wear layer resists scratches, stains and wear
- Dry back planks stand up to high-traffic and high moisture



NATURAL PERSONALITY™ 2
Walnut
Charcoal D1024

PRODUCT STRUCTURE

NATURAL PERSONALITY™ 2 GOOD LUXURY FLOORING

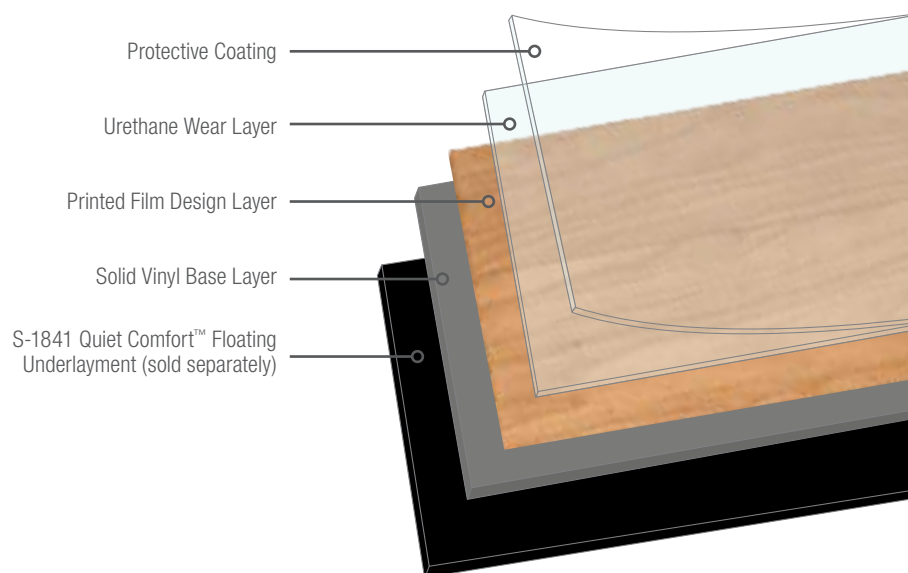



HEARTH OAK
Wheat D1032
6" x 36" planks



HONEY PINE
Natural D1033
6" x 36" planks



AGED WALNUT
Sepia D1034
6" x 36" planks



MEDIUM WALNUT
Brown D1035
6" x 36" planks



WINDSWEPT PLANK
Driftwood D1036
6" x 36" planks



DARK RUSTIC
Umber D1037
6" x 36" planks



HICKORY
Rustic Brown D1023
6" x 36" planks



WALNUT
Charcoal D1024
6" x 36" planks



WHITE OAK
Heather Gray D1025
6" x 36" planks



BRUSHED OAK
Natural D1026
6" x 36" planks



BRUSHED OAK
Caramel D1027
6" x 36" planks



BRADBURY OAK
Weathered Gray D1028
6" x 36" planks



BRADBURY OAK
Dusky Brown D1029
6" x 36" planks



THORNDALE OAK
Cinder Gray D1030
6" x 36" planks



HAVENWOOD
Cinnamon D1031
6" x 36" planks

SPECIFICATIONS

OVERALL THICKNESS
2 mm

WEAR LAYER
6 mil

INSTALLATION
Glue Down

LIMITED WARRANTY
Res: 7-year Limited

PLANK SIZE
6" X 36"

PIECES PER CARTON
24 pcs

SQ. FT. PER CARTON
36 sq ft

AMERICAN PERSONALITY™ 12

BETTER LUXURY FLOORING

- 20 unique planks per design with additional variation – virtually eliminates visible pattern repeat
- 100% waterproof* planks are ideal for high-moisture areas including: kitchens, bathrooms, mudrooms and basements
- Tough fiberglass reinforced structure requires no acclimation in most installations**
- Urethane wear layer protects against scratches scuffs, and stains



Armstrong® Luxury Flooring is proudly made in Stillwater, Oklahoma with global and domestic content.



AMERICAN PERSONALITY™ 12
Lakehouse Hickory
Greige Twist K1000

PRODUCT STRUCTURE

AMERICAN PERSONALITY™ 12 BETTER LUXURY FLOORING

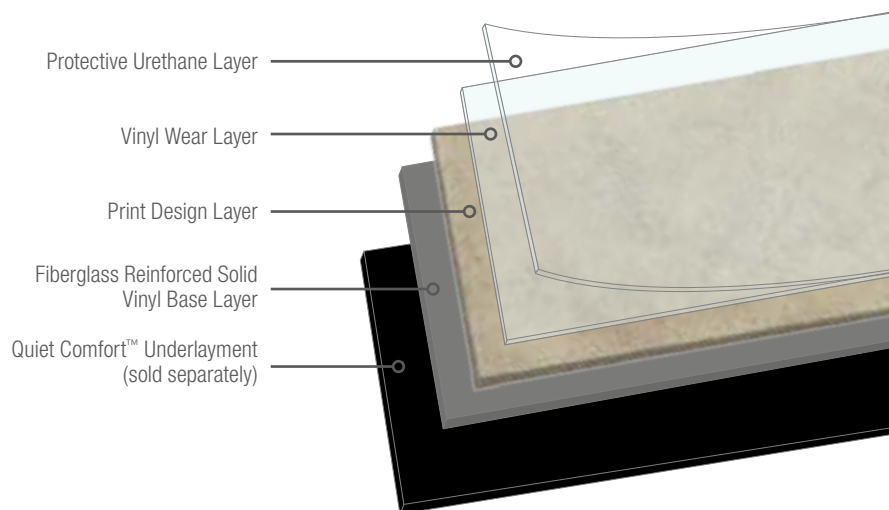

*When exposed to water American Personality 12 planks will not swell, buckle or lose integrity. See warranty for details.
** Installation environments need to be temperature controlled. See installation instructions for details.



LAKEHOUSE HICKORY
Greige Twist K1000
6.5" x 48" planks



LAKEHOUSE HICKORY
Artesian Gray K1001
6.5" x 48" planks



LAKEHOUSE HICKORY
Alpine Frost K1002
6.5" x 48" planks



LAKEHOUSE HICKORY
Burnished Honey K1003
6.5" x 48" planks

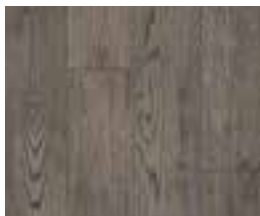

CRAFTED OAK
Essential Beige K1010
6.5" x 48" planks



CRAFTED OAK
Nostalgic Russet K1011
6.5" x 48" planks

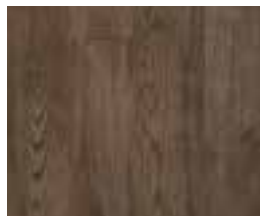

CRAFTED OAK
Bronzed Roots K1012
6.5" x 48" planks



CRAFTED OAK
Smokehouse Brown K1013
6.5" x 48" planks



CRAFTED OAK
Crimson Earth K1014
6.5" x 48" planks



RICHLAND WALNUT
Indigo Blush K1020
6.5" x 48" planks



RICHLAND WALNUT
Umber K1021
6.5" x 48" planks



RICHLAND WALNUT
Charcoal K1022
6.5" x 48" planks

SPECIFICATIONS

OVERALL THICKNESS
2 mm

WEAR LAYER
12 mil

INSTALLATION
Glue Down

LIMITED WARRANTY
Res: 15-year Limited
Com: 7-year Limited

PLANK SIZE
6.5" X 48"

PIECES PER CARTON
16 pcs

SQ. FT. PER CARTON
34.66 sq ft

VIVERO®

GOOD LUXURY FLOORING

- Eight beautiful on-trend wood designs and colors
- 6mil Urethane Plus wear layer
- Made for real life by enduring water, pets, kids and heavy traffic
- 100% Waterproof*

MAXIMUM INSTALLATION VERSATILITY

- G** **GLUE DOWN** Traditional installation and unique design options
- L** **LOCKING** Traditional angle locking – Quick and simple angle locking technology that spans most subfloors with minimal prep

MADE IN THE USA



Vivero luxury flooring is manufactured in Lancaster, Pennsylvania, with global and domestic content.



VIVERO® Good
Century Barnwood
Weathered Gray U5010/U6010

PRODUCT STRUCTURE VIVERO® GOOD LUXURY FLOORING

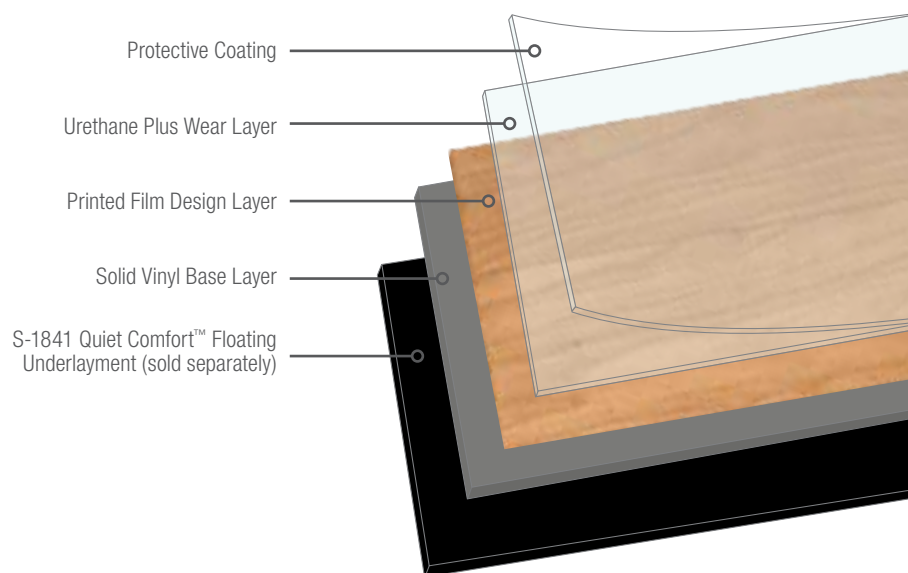

*When exposed to water Vivero planks will not swell, buckle or lose integrity. See warranty for details.



CENTURY BARNWOOD
Weathered Gray
U5010/U6010



WABASH HICKORY
Tavern Brown
U5031/U6031



CHARLESTOWN OAK
Platinum
U5040/U6040



CHARLESTOWN OAK
Mocha
U5041/U6041



RURAL RECLAIMED
Russet
U5051/U6051



WEST SIDE WALNUT
Underground Brown
U5070/U6070



WEST SIDE WALNUT
Bistro Brown
U5071/U6071



WESTON OAK
Golden Glaze
U5080/U6080

SPECIFICATIONS

OVERALL THICKNESS
Glue Down - 2.0 mm
Locking - 3.5 mm

WEAR LAYER
6 mil - Urethane Plus

INSTALLATION
Glue Down - 6"
Locking - 5-5/8"

LIMITED WARRANTY
Res: 15-year Limited
Com: 5-year Limited

PLANK SIZE
6" x 36"

PIECES PER CARTON
Glue Down - 24 pcs
Locking - 16 pcs
per carton

SQ. FT. PER CARTON
Glue Down - 36 sq.ft.
Locking - 33.2 sq.ft.

LUXURY FLOORING ACCESSORIES

UNDERLAYMENT

Engineered to reduce sound and compensate for slight subfloor irregularities, Armstrong® Quiet Comfort™ underlayment is ideal for use with Armstrong LVT flooring.

Turn any glue down LVT into a floating floor with S-1841 Quiet Comfort™ Floating Underlayment. Float underlayment over subfloor and glue LVT to underlayment. Floating underlayment allows for easy cut out and replace for quick fixes.

S-1840 Quiet Comfort™ Luxury Flooring Underlayment

- Designed for use with Armstrong Luxury Flooring, Alterna®, and LVT products
- Excellent acoustic barrier for through-the-floor and in-room footfall noise reduction
- Cross-linked polypropylene provides moisture barrier which resists mold and mildew
- Weight: 6 lbs./roll
- STC/IIC: 62/64

300 sf Roll



S-1841 Quiet Comfort™ Floating Underlayment

- Turn any Alterna or LVT installation into a floating floor
- Reduces subfloor preparation and simplifies installation
- Construction: saturated polyester provides strength and stability
- STC/IIC: 62/57

100, 350 or 1,600 sf Rolls



COORDINATING TRIMS

There's a trim designed to match our Luxury Flooring products.

All products have:

- Multi-purpose trim - provides a seamless look when transitioning from luxury flooring to another flooring surface
- Overlap stair nose trim - finishes the edge of stairs and step downs or landings

Additionally for Pryzm™ and Rigid Core Elements™ we offer flush stairnose and endcap profiles.



Multi-purpose trim shown

LUXURY FLOORING QUICK REFERENCE GUIDE

LUXURY FLOORING/LVT

RIGID CORE LUXURY FLOORING									
	Collection	Structure	Wear Layer	Finish	Limited Warranty	Installation Method	Edge Treatment	Sizes	Designs
PREMIUM	PRYZM™	6.5 mm	AC4 Commercial	VisionGuard®	Res: Lifetime Com: 15-year	Locking	Micro-bevel	4'5" x 48" 5" x 48" 6" x 48" 7" x 48"	Wood
BEST									
BETTER	RIGID CORE VANTAGE™	6.0 mm	20 mil	Urethane	Res: 30-year Com: 15-year	Drop-lock	Micro-bevel	7" x 60" 9" x 60"	Wood
BETTER	LUXE® PLANK WITH RIGID CORE TECHNOLOGY	8.0 mm	20 mil	UV Acrylic	Res: 30-year Com: 10-year	Locking	Micro-bevel	6" x 48" 7" x 48" 12" x 24"	Wood Stone
	RIGID CORE ELEMENTS™	5.0 mm	12 mil	Urethane	Res: 30-year Com: 7-year	Locking	Micro-bevel	6" x 48" 7" x 48"	Wood

GLUELESS LUXURY FLOORING									
	Collection	Structure	Wear Layer	Finish	Limited Warranty	Installation Method	Edge Treatment	Sizes	Designs
BETTER	LUXE® PLANK WITH FASTAK™ INSTALLATION	4.0 mm	12 mil	Urethane	Res: 30-year Com: 10-year	Self-adhering	Pressed bevel	6" x 48" 7" x 48" 12" x 24"	Wood Stone
GOOD									
GOOD	LUXE® PLANK WITH LYNX® INSTALLATION	2.8 mm	12 mil	Urethane	Res: 15-year Com: 5-year	Floating	Square	6" x 36"	Wood
VALUE	VIVERO® GOOD	3.5 mm	6 mil	Urethane Plus	Res: 15-year Com: 5-year	Locking	Square	6" x 36"	Wood
	LUXE® PLANK WITH LYNX® INSTALLATION	2.8 mm	6 mil	Urethane	Res: 10-year Com: 7-year	Floating	Square	6" x 36" 12" x 36"	Wood Stone

GLUE DOWN LUXURY FLOORING									
	Collection	Structure	Wear Layer	Finish	Limited Warranty	Installation Method	Edge Treatment	Sizes	Designs
BETTER	PARALLEL® 20	2.0 mm	20 mil	Urethane	Res: 30-year Com: 15-year	Glue Down	Bevel	6" x 48" 12" x 24"	Wood Stone
BETTER									
BETTER	PARALLEL® 12	2.5 mm	12 mil	Urethane	Res: 15-year Com: 7-year	Glue Down	Bevel	6" x 48" 12" x 24"	Wood Stone
GOOD	AMERICAN PERSONALITY™ 12	2.0 mm	12 mil	Urethane	Res: 15-year Com: 7-year	Glue Down	Square	6.5" x 48"	Wood
GOOD	VIVERO® GOOD	2.0 mm	6 mil	Urethane Plus	Res: 15-year Com: 5-year	Glue Down	Square	6" x 36"	Wood
	NATURAL PERSONALITY™ 2	2.0 mm	6 mil	Urethane	Res: 7-year	Glue Down	Square	6" x 36"	Wood

ACOUSTICS DATA

RIGID CORE ACOUSTICS DATA

Structure	Product Name	Installation Method	Ceiling	Underlayment	STC	IIC	ΔIIC
6" concrete slab	Pryzm	Loose Lay	No	None	50	53	23
6" concrete slab	Pryzm	Loose Lay	Yes	None	63	69	-
6" concrete slab	Pryzm	Loose Lay	No	S-1840	51	53	23
6" concrete slab	Pryzm	Loose Lay	Yes	S-1840	61	66	-
6" concrete slab	Pryzm	Loose Lay	No	S-1841	51	52	23
6" concrete slab	Pryzm	Loose Lay	Yes	S-1841	62	65	-
8" concrete slab	Pryzm	Loose Lay	No	None	51	50	18
8" concrete slab	Pryzm	Loose Lay	No	S-1841	50	50	18
6" concrete slab	Rigid Core Vantage	Loose Lay	No	None	50	48	21
6" concrete slab	Rigid Core Vantage	Loose Lay	Yes	None	62	67	-
6" concrete slab	Rigid Core Vantage	Loose Lay	No	S-1840	50	50	23
6" concrete slab	Rigid Core Vantage	Loose Lay	Yes	S-1840	61	66	-
6" concrete slab	Rigid Core Vantage	Loose Lay	No	S-1841	51	54	24
6" concrete slab	Rigid Core Vantage	Loose Lay	Yes	S-1841	61	65	-
6" concrete slab	Rigid Core Elements	Loose Lay	No	None	49	51	21
6" concrete slab	Rigid Core Elements	Loose Lay	Yes	None	63	64	-
6" concrete slab	Rigid Core Elements	Loose Lay	No	S-1840	50	52	21
6" concrete slab	Rigid Core Elements	Loose Lay	Yes	S-1840	62	67	-
6" concrete slab	Rigid Core Elements	Loose Lay	No	S-1841	52	56	27
6" concrete slab	Rigid Core Elements	Loose Lay	Yes	S-1841	61	68	-
8" concrete slab	Rigid Core Elements (attached pad)	Loose Lay	No	None	52	53	21
California Slab	Rigid Core Elements (attached pad)	Loose Lay	Yes	None	56	51	-
6" concrete slab	Luxe Plank Rigid Core, Parallel PC	Loose Lay	No	None	49	53	23
6" concrete slab	Luxe Plank Rigid Core, Parallel PC	Loose Lay	Yes	None	62	67	-
6" concrete slab	Luxe Plank Rigid Core, Parallel PC	Loose Lay	Yes	None	61	66	-
6" concrete slab	Luxe Plank Rigid Core, Parallel PC	Loose Lay	No	S-1840	49	51	21
6" concrete slab	Luxe Plank Rigid Core, Parallel PC	Loose Lay	Yes	S-1840	60	66	-
6" concrete slab	Luxe Plank Rigid Core, Parallel PC	Loose Lay	No	S-1841	50	54	24
6" concrete slab	Luxe Plank Rigid Core, Parallel PC	Loose Lay	Yes	S-1841	61	66	-
8" concrete slab	Luxe Plank Rigid Core, Parallel PC	Loose Lay	No	None	51	50	18
California Slab	Luxe Plank Rigid Core, Parallel PC	Loose Lay	Yes	None	56	50	-
California Slab	Luxe Plank Rigid Core, Parallel PC	Loose Lay	Yes	S-1840	56	52	-
California Slab	Luxe Plank Rigid Core, Parallel PC	Loose Lay	Yes	S-1841	59	53	-

LVT ACOUSTICS DATA

6" concrete slab	Luxe Plank with FasTak, Natural Creations with I-Set None		Yes	None	-	53	-
California Slab	Luxe Plank with FasTak, Natural Creations with I-Set S-288 Adhesive (Full Spread) (Two Layer glue down)		Yes	S-1840	-49	-	-
6" concrete slab	Luxe Value with Lynx, Luxe Plank Good with Lynx	None	Yes	None	-	46	-
6" concrete slab	Luxe Value with Lynx, Luxe Plank Good with Lynx	Peel and Stick and S-288 Adhesive for underlayment	Yes	S-1840	-	65	-
California Slab	Luxe Value with Lynx, Luxe Plank Good with Lynx	S-288 Adhesive (Full Spread) (Two Layer glue down)	Yes	S-1840	-	49	-
8" concrete slab	Parallel 12	S-288 Adhesive (Full Spread)	No	S-1840	54	52	19
6" concrete slab	Parallel 20	S-288 Adhesive (Full Spread)	Yes	S-1840	63	55	-
8" concrete slab	Natural Personality 2	S-288 Adhesive (Full Spread)	No	None	54	33	3
6" concrete slab	Natural Personality, Natural Living, Parallel 12	S-288 Adhesive (Full Spread)	Yes	S-1840	62	64	-
6" concrete slab	Natural Personality, Natural Living, Parallel 12	S-288 Adhesive (Full Spread)	No	None	-	31	-
6" concrete slab	Natural Personality, Natural Living, Parallel 12	S-288 Adhesive (Full Spread)	Yes	None	-	44	-
California Slab	Natural Personality, Natural Living, Parallel 12	S-288 Adhesive	Yes	S-1840	57	53	-
6" concrete slab	Natural Personality	Adhered	Yes	FloorMuffler	62	64	-
6" concrete slab	Natural Personality	Adhered	Yes	Foam Silencer	62	65	-
6" concrete slab	Natural Personality	Adhered	Yes	Manning Wunderlayment	63	62	-
6" concrete slab	American Personality 12	S-288 Adhesive (Full Spread)	No	None	53	36	10
6" concrete slab	American Personality 12	S-288 Adhesive (Full Spread)	Yes	None	62	50	-
6" concrete slab	American Personality 12	S-288 Adhesive (Full Spread) (Two layer glued down)	No	S-1840	50	49	23
6" concrete slab	American Personality 12	S-288 Adhesive (Full Spread)	Yes	S-1840	62	66	-
6" concrete slab	American Personality 12	S-288 Adhesive (Full Spread)	No	S-1841	51	41	14
6" concrete slab	American Personality 12	S-288 Adhesive (Full Spread)	Yes	S-1841	62	57	-
California Slab	Natural Creations	S-288 Adhesive (Full Spread) (Two Layer glue down)	Yes	S-1840	-	49	-
6" concrete slab	Natural Creations LVT	S-288 Adhesive (Full Spread)	Yes	None	63	50	-
6" concrete slab	Natural Creations LVT	S-288 Adhesive (Full Spread)	Yes	S-1840	62	65	-
6" concrete slab	Natural Creations LVT	S-288 Adhesive (Full Spread) (Two layer glued down)	Yes	S-1840	-	65	-
6" concrete slab	Natural Creations Solid Vinyl Tile	S-288 Adhesive (Full Spread)	No	None	54	38	11
6" concrete slab	Vivero Best	S-288 Adhesive (Full Spread)	Yes	S-1840	62	66	-
6" concrete slab	Vivero Better Locking, Vivero Best Locking	Loose Lay	No	None	52	39	13
6" concrete slab	Vivero Better Locking, Vivero Best Locking	Loose Lay	Yes	None	63	44	-
6" concrete slab	Vivero Better Locking, Vivero Best Locking	Loose Lay	No	S-1840	52	53	23
6" concrete slab	Vivero Better Locking, Vivero Best Locking	Loose Lay	Yes	S-1840	62	68	-
6" concrete slab	Vivero Better Locking, Vivero Best Locking	Loose Lay	No	S-1841	52	44	18
6" concrete slab	Vivero Better Locking, Vivero Best Locking	Loose Lay	Yes	S-1841	62	50	-
6" concrete slab	Vivero Good Locking	Loose Lay	Yes	None	62	49	-
6" concrete slab	Vivero Good Locking	Loose Lay	Yes	S-1840	62	66	-
6" concrete slab	Vivero Good, Vivero Better, Parallel 6i, Parallel 12i	S-288 Adhesive (Full Spread)	No	None	53	33	7
6" concrete slab	Vivero Good, Vivero Better, Parallel 6i, Parallel 12i	S-288 Adhesive (Full Spread)	Yes	None	62	46	-
6" concrete slab	Vivero Good, Vivero Better, Parallel 6i, Parallel 12i	S-288 Adhesive (Full Spread)	No	S-1840	52	53	23
6" concrete slab	Vivero Good, Vivero Better, Parallel 6i, Parallel 12i	S-288 Adhesive (Full Spread)	Yes	S-1840	63	65	-
6" concrete slab	Vivero Good, Vivero Better, Parallel 6i, Parallel 12i	S-288 Adhesive (Full Spread)	No	S-1841	53	39	13
6" concrete slab	Vivero Good, Vivero Better, Parallel 6i, Parallel 12i	S-288 Adhesive (Full Spread)	Yes	S-1841	62	52	-

VINYL TILE

CALIBER™ PREMIUM VINYL TILE

- Durable vinyl tiles provide superior resistance to wear and stain
- Easy to care for vinyl wear layer (6 mil)
- Self-adhesive and glue down installation options
- Lifetime limited residential warranty

MADE IN THE USA



Armstrong® Vinyl Flooring is manufactured with global and domestic content.

AFTON SERIES™ BETTER & UNITS™ GOOD VINYL TILE

- Variety of designs to please every style and taste
- Vinyl no-wax wear layer (2.6 mil) is easy to clean and maintain
- Easy-to-install adhesive-backed tile

MADE IN THE USA



Armstrong® Vinyl Flooring is manufactured with global and domestic content.

PRODUCT STRUCTURE CALIBER PREMIUM VINYL TILE

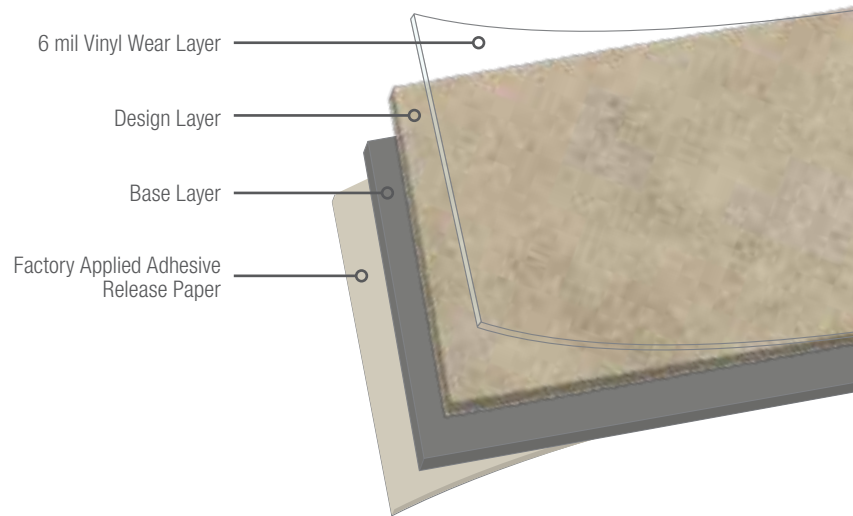

PRODUCT STRUCTURE AFTON SERIES BETTER & UNITS GOOD VINYL TILE

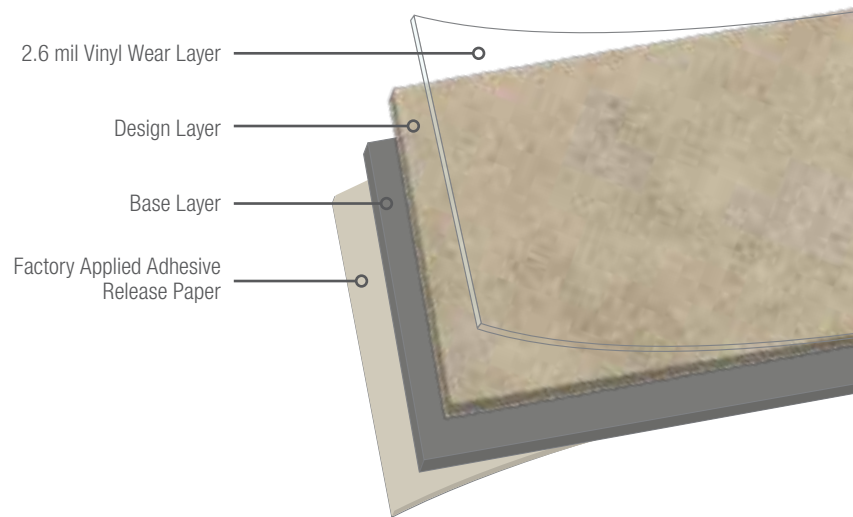

CALIBER PREMIUM



BARDWIN
Almond
21661 / 51661*



WALNUT HILL
Sand
21730

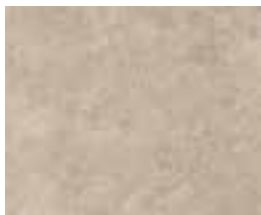

GROUTED CERAMIC
Pumice
21750 / 51750*



NEW SLATE
Mesa Stone
21745



MULTISTONE
Clay
21737



MULTISTONE
Sand
21736

SPECIFICATIONS

OVERALL THICKNESS
6 mil

TILE SIZE
12" X 12"

PIECES PER CARTON
45 pcs

SQ. FT. PER CARTON
45 sq ft

LIMITED WARRANTY
Res: Lifetime Limited

*Dry-back Glue Down

AFTON SERIES BETTER



DIAMOND JUBILEE
Black / White
24320



CHISLED STONE
Cliffstone
24495

SPECIFICATIONS

OVERALL THICKNESS
Afton Series - 1.65 mm
Units - 1.14 mm

TILE SIZE
12" X 12"

PIECES PER CARTON
45 pcs

SQ. FT. PER CARTON
45 sq ft

LIMITED WARRANTY
Afton Series
Res: 10-year Limited
Units
Res: 5-year Limited

UNITS GOOD



ROCKTON
Cream
25240



ROCKPORT MARBLE
Sand
25285



CRISWOOD
Russet Oak
25290



RIDGEDALE
Sand
25300



RIDGEWAY II
Beige
25310



RIDGEWAY II
Multicolor
25311



OVERLOOK II
Sandstone
25315

ALTERNA® PLANK

ENGINEERED TILE

- Wide array of wood visuals in a 6" x 36" groutable format
- Innovative Diamond 10® Technology makes Alterna plank floors scratch, scuff and stain resistant and repels dirt for easy cleaning
- Installs over minor subfloor irregularities without the risk of cracking, unlike ceramic tile
- Faster, easier and cleaner to install than natural stone or ceramic tile - less time and labor means installation will cost less
- Enhance the authentic tile look with Armstrong S-693 FlexStrong™ Grout with premixed sanded acrylic
- Lifetime limited residential and 5-year limited light commercial warranty



MADE IN THE USA



Alterna® floors are manufactured in Kankakee, IL and Lancaster, PA and feature global and domestic content.



ALTERNA® PLANK
Established Goodness
Province Grove D0001, Craftsman Steel D0002

PRODUCT STRUCTURE

ALTERNA PLANK PREMIUM ENGINEERED TILE

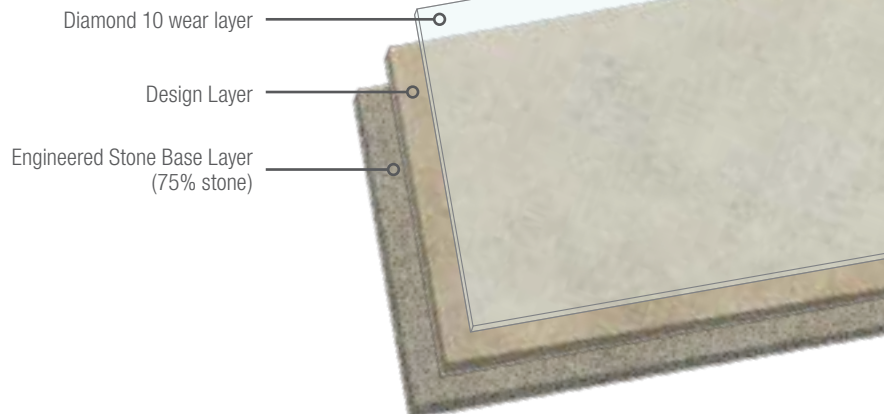

SPECIFICATIONS

OVERALL THICKNESS
4.1 mm

SIZE
6" X 36"

PIECES PER CARTON
12 pcs

SQ. FT. PER CARTON
18 sq ft

LIMITED WARRANTY
Res: Lifetime Limited
Lt. Com: 5-year Limited



J10 Mist

TIME FOR TEA
Pigment Degree D0015
6" x 36" planks



F6 Driftwood

TIME FOR TEA
Spring Dust D0013
6" x 36" planks



G7 Cocoa

TIME FOR TEA
Conestoga Wagon D0014
6" x 36" planks



H8 Shale

TIME FOR TEA
Forgotten Forest D0012
6" x 36" planks



F6 Driftwood

MILES OF TRAIL
Butcher's Paper D0011
6" x 36" planks



C3 Sandalwood

MILES OF TRAIL
Olsen House D0010
6" x 36" planks



D4 Mushroom

MILES OF TRAIL
Gateway Gray D0009
6" x 36" planks



F6 Driftwood

RUSTIC ISOLATION
Half Tide D0007
6" x 36" planks



D4 Mushroom

RUSTIC ISOLATION
Dockside Shadow D0008
6" x 36" planks



D4 Mushroom

RUSTIC ISOLATION
Stolen Cargo D0006
6" x 36" planks



B2 Smoke

IDEAL CANDIDATE
Opaque Passage D0003
6" x 36" planks



D4 Mushroom

IDEAL CANDIDATE
Dry Brush Charcoal D0004
6" x 36" planks



D4 Mushroom

IDEAL CANDIDATE
Studio Easel D0005
6" x 36" planks



D4 Mushroom

ESTABLISHED GOODNESS
Province Grove D0001
6" x 36" planks



D4 Mushroom

ESTABLISHED GOODNESS
Craftsman Steel D0002
6" x 36" planks

Suggested grout color shown under swatch.
For more grout recommendations see Alterna Accessories on page 43.

ALTERNA® ENGINEERED TILE

ALTERNA® RESERVE & ALTERNA® ENGINEERED TILE

- Extensive collection with tile-to-tile variation – includes contemporary and authentic slate, marble, terracotta, travertine, wood, metal, linen and concrete inspired designs
- Scratch and stain resistant finish with advanced nano aluminum oxide
- Installs over minor subfloor irregularities without the risk of cracking, unlike ceramic tile
- Faster, easier and cleaner to install than natural stone or ceramic tile - less time and labor means installation will cost less
- Enhance the authentic tile look with Armstrong S-693 FlexStrong™ Grout with premixed sanded acrylic
- Lifetime limited residential and 5-year limited light commercial warranty



MADE IN THE USA



Alterna® floors are manufactured in Kankakee, IL and Lancaster, PA and feature global and domestic content.



ALTERNA® RESERVE
Historic District
Past Perfect Design Kit D7360

PRODUCT STRUCTURE ALTERNA PREMIUM ENGINEERED TILE

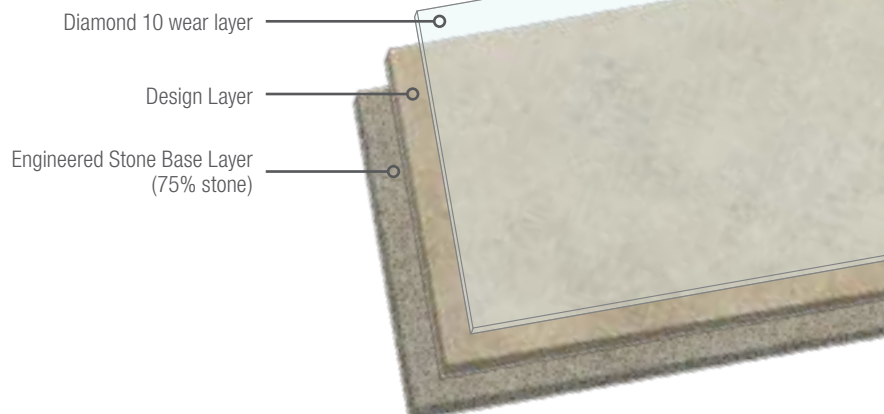

ALTERNA® RESERVE



HISTORIC DISTRICT
Blached Mist
8" x 16" D5350
12" x 24" D7350



HISTORIC DISTRICT
Reclaim Bay
8" x 16" D5355
12" x 24" D7355



HISTORIC DISTRICT
Farmhouse Linen
8" x 16" D5345
12" x 24" D7345



HISTORIC DISTRICT
Blached Mist
Opus Pattern Kit
16" x 16", 8" x 16", 8" x 8" D8350



HISTORIC DISTRICT
Reclaim Bay
Opus Pattern Kit
16" x 16", 8" x 16", 8" x 8" D8355

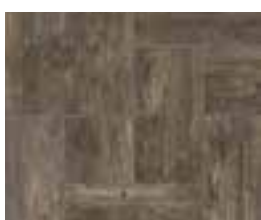

HISTORIC DISTRICT
Farmhouse Linen
Opus Pattern Kit
16" x 16", 8" x 16", 8" x 8" D8345



PAST PERFECT KIT
8" x 16" D5360
12" x 24" D7360
(Even blend of all Historic District skus)



GRAIN DIRECTIONS
Antiqued Ivory
8" x 16" D5365
12" x 24" D7365



GRAIN DIRECTIONS
Heirloom Greige
8" x 16" D5375
12" x 24" D7375



GRAIN DIRECTIONS
Tobacco Etch
8" x 16" D5370
12" x 24" D7370



GRAIN DIRECTIONS
Antiqued Ivory
Opus Pattern Kit
16" x 16", 8" x 16", 8" x 8" - D8365



GRAIN DIRECTIONS
Heirloom Greige
Opus Pattern Kit
16" x 16", 8" x 16", 8" x 8" - D8375

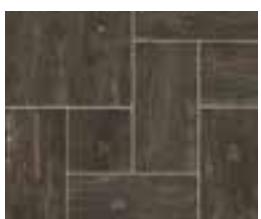

GRAIN DIRECTIONS
Tobacco Etch
Opus Pattern Kit
16" x 16", 8" x 16", 8" x 8" - D8370



HERITAGE CREATIONS KIT
12" x 24" - D7385
8" x 16" - D5385
(Even blend of all Grain Directions skus)

SPECIFICATIONS

OVERALL THICKNESS
4.1 mm

SIZE
16" X 16"
12" X 24"
8" X 16"
Opus Kit:
(16" X 16", 8" X 16",
8" X 8")

PIECES PER CARTON
16" X 16" - 14 pcs
12" X 24" - 12 pcs
8" X 16" - 24 pcs
Opus Kit - 24 pcs

SQ. FT. PER CARTON
16" X 16" - 24.89 sq ft
12" X 24" - 24.13 sq ft
8" X 16" - 21.17 sq ft
Opus Kit - 24.78 sq ft

LIMITED WARRANTY
Res: Lifetime Limited
Lt. Com: 5-year Limited

ALTERNA® ENGINEERED TILE

ALTERNA® RESERVE



J10 Mist
MOSELLE VALLEY
Honeysuckle
16" x 16" D4320



F6 Driftwood
MOSELLE VALLEY
Sunrise
16" x 16" D4322



D4 Mushroom
MOSELLE VALLEY
Forest Green/Copper
16" x 16" D4324



B2 Smoke
ALLEGHENY SLATE
Italian Earth
16" x 16" D4330
12" x 24" D7330



D4 Mushroom
ALLEGHENY SLATE
Copper Mountain
16" x 16" D4332
12" x 24" D7332



L12 Corn Silk
ATHENIAN TRAVERTINE
Honey Onyx
16" x 16" D4340
12" x 24" D7340



F6 Driftwood
ATHENIAN TRAVERTINE
Provincial Bisque
16" x 16" D4342
12" x 24" D7342

SPECIFICATIONS

OVERALL THICKNESS
4.1 mm

WEAR LAYER
12 mil

INSTALLATION
Self-adhering

LIMITED WARRANTY
Res: Lifetime Limited
Lt. Com: 5-year Limited

PLANK SIZE
12" X 24"
6" X 48"
7.2" X 48"

PIECES PER CARTON
12" - 12 pcs
6" - 12 pcs
7" - 10 pcs

SQ. FT. PER CARTON
12" - 24 sq ft
6" - 24 sq ft
7" - 24.3 sq ft

Suggested grout color shown under swatch.
For more grout recommendations see Alterna Accessories on page 43.

ALTERNA®



I9 Sea Shell

TUSCAN PATH
Cameo Brown
16" x 16" D4170



D4 Mushroom

TUSCAN PATH
Dove Gray
16" x 16" D4171
12" x 24" D7171



G7 Coaco

TUSCAN PATH
Antique Gold
16" x 16" D4172
12" x 24" D7172



E5 Gypsum

DURANGO
Cream
16" x 16" D4155
12" x 24" D7155



C3 Sandalwood

DURANGO
Deep Gold
16" x 16" D4156
12" x 24" D7156



J10 Mist

DURANGO
Bleached Sand
16" x 16" D4157



C3 Sandalwood

DURANGO
Clay
16" x 16" D4159
12" x 24" D7159



F6 Driftwood

LA PLATA
Taupe / Gray
16" x 16" D4135
12" x 24" D7135



F6 Driftwood

LA PLATA
Caramel
16" x 16" D4136
12" x 24" D7136



J10 Mist

MESA STONE
Chalk
16" x 16" D4105
12" x 24" D7105



F6 Driftwood

MESA STONE
Beige
16" x 16" D4106



D4 Mushroom

MESA STONE
Gray / Brown
16" x 16" D4107
12" x 24" D7107



H8 Shale

MESA STONE
Canyon Shadow
16" x 16" D4110



H8 Shale

MESA STONE
Charcoal
16" x 16" D4111
12" x 24" D7111



D4 Mushroom

MESA STONE
Canyon Sun
16" x 16" D4112
12" x 24" D7112



B2 Smoke

MESA STONE
Light Gray
16" x 16" D4113

SPECIFICATIONS

OVERALL THICKNESS
4.1 mm

SIZE
16" X 16"
12" X 24"
8" X 16"

PIECES PER CARTON
16" X 16" - 14 pcs
12" X 24" - 12 pcs
8" X 16" - 24 pcs

SQ. FT. PER CARTON
16" X 16" - 24.89 sq ft
12" X 24" - 24.13 sq ft
8" X 16" - 21.17 sq ft

LIMITED WARRANTY
Res: Lifetime Limited
Lt. Com: 5-year Limited

Suggested grout color shown under swatch.
For more grout recommendations see Alterna Accessories on page 43.

ALTERNA® ENGINEERED TILE

ALTERNA®



MESA STONE
Chocolate
16" x 16" D4109

D4 Mushroom



MESA STONE
Terracotta / Clay
16" x 16" D4114
12" x 24" D7114

F6 Driftwood



ARTISAN FORGE
Polished Pewter
16" x 16" D4193

B2 Smoke



ARTISAN FORGE
Iron Ore
16" x 16" D4195

D4 Mushroom

SPECIFICATIONS

OVERALL THICKNESS
4.1 mm

PLANK SIZE
16" X 16"
12" X 24"
8" X 16"

PIECES PER CARTON
16" X 16" - 14 pcs
12" X 24" - 12 pcs
8" X 16" - 24 pcs

SQ. FT. PER CARTON
16" X 16" - 24.89 sq ft
12" X 24" - 24.13 sq ft
8" X 16" - 21.17 sq ft

LIMITED WARRANTY
Res: Lifetime Limited
Lt. Com: 5-year Limited



ARTISAN FORGE
Silver Shimmer
16" x 16" D4196

J10 Mist



ENCHANTED FOREST
Night Owl
8" x 16" D5197

H8 Shale



ENCHANTED FOREST
Tender Twig
8" x 16" D5198

D4 Mushroom



ENCHANTED FOREST
Forest Fog
8" x 16" D5199

K11 Silver Cloud



URBAN GALLERY
Gallery Gray
8" x 16" D5117

K11 Silver Cloud



URBAN GALLERY
High-rise Neutral
8" x 16" D5118

B2 Smoke



URBAN GALLERY
Loft Gray
8" x 16" D5119

D4 Mushroom



MULTISTONE
Gray Dust
16" x 16" D4121
12" x 24" D7121

F6 Driftwood



MULTISTONE
Caramel Gold
16" x 16" D4123

C3 Sandalwood



MULTISTONE
Slate Blue
16" x 16" D4125
12" x 24" D7125

D4 Mushroom



WHISPERED ESSENCE
Hint Of Gray
8" x 16" D5176

K11 Silver Cloud



SISTINE
White
16" x 16" D4150
12" x 24" D7150

E5 Gypsum

Suggested grout color shown under swatch.
For more grout recommendations see Alterna Accessories on page 43.

ALTERNA®



MESA STONE
Moss
16" x 16" D4108
12" x 24" D7108



MESA STONE
Fieldstone
16" x 16" D4115
12" x 24" D7115



MULTISTONE
White
16" x 16" D4120
12" x 24" D7120



MULTISTONE
Cream
16" x 16" D4122
12" x 24" D7122

SPECIFICATIONS

OVERALL THICKNESS
4.1 mm

SIZE
16" X 16"
12" X 24"
8" X 16"

PIECES PER CARTON
16" X 16" - 14 pcs
12" X 24" - 12 pcs
8" X 16" - 24 pcs

SQ. FT. PER CARTON
16" X 16" - 24.89 sq ft
12" X 24" - 24.13 sq ft
8" X 16" - 21.17 sq ft

LIMITED WARRANTY
Res: Lifetime Limited
Lt. Com: 5-year Limited



LA PLATA
Crème Fresh
16" x 16" D4137
12" x 24" D7137



SISTINE
Bisque
16" x 16" D4151
12" x 24" D7151



DURANGO
Buff
16" x 16" D4158
12" x 24" D7158



TUSCAN PATH
Beige Blush
16" x 16" D4173



ARTISAN FORGE
Golden Glaze
16" x 16" D4194
12" x 24" D7194



SAWNMILL CREATIONS
Prairie Will
12" x 24" D7142



SAWNMILL CREATIONS
Evening Dew
12" x 24" D7143



HARVEST BLOCK
Meadowed Highpoint
12" x 24" D7144



HARVEST BLOCK
Whisper Chill
12" x 24" D7145

ALTERNA® ENGINEERED TILE

The natural beauty of Alterna isn't limited to floors! Use Alterna, with or without grout as a decorative backsplash, accent wall or other focal point to bring added style to your space.



**Alterna is not recommended for shower walls, fireplace surrounds or any wall application that exposes it to continuous saturation or temperatures above 300°F.*

ALTERNA® ACCESSORIES

UNDERLAYMENT

The use of quality underlayment is critical to a successful installation and should be installed prior to laying flooring. Use the pre-applied tape for a seamless moisture barrier, especially over concrete.

S-1840 Quiet Comfort™ Luxury Flooring Underlayment

- Designed for use with Armstrong Luxury Flooring, Alterna®, and LVT products
- Excellent acoustic barrier for through-the-floor and in-room footfall noise reduction
- Cross-linked polypropylene provides moisture barrier which resists mold and mildew
- Weight: 6 lbs./roll
- STC/IIC: 62/64



S-1841 Quiet Comfort™ Floating Underlayment

- Turn any Alterna or LVT installation into a floating floor
- Reduces subfloor preparation and simplifies installation
- Construction: saturated polyester provides strength and stability
- STC/IIC: 62/57



COORDINATING TRIMS

The Finishing Touch Coordinating Multi-Purpose & Stairnose Trim

- Matching trim for all Alterna® designs
- Multi-Purpose trim provides a seamless look when transitioning from Alterna® engineered tile to another flooring surface
- Stairnose trim finishes the edges of stairs, step downs or landings



ENGINEERED TILE

ALTERNA COORDINATED GROUT

WARM TONES		
	E5 Gypsum	Gal:693408E Qt:693124E
	I9 Sea Shell	Gal:693408I Qt:693124I
	F6 Driftwood	Gal:693408F Qt:693124F
	L12 Corn Silk	Gal:693408L Qt:693124L
	C3 Sandalwood	Gal:693408C Qt:693124C
	G7 Cocoa	Gal:693408G Qt:693124G

COOL TONES		
	A1 Glacier	Gal:693408A Qt:693124A
	J10 Mist	Gal:693408J Qt:693124J
	K11 Silver Cloud	Gal:693408K Qt:693124K
	B2 Smoke	Gal:693408B Qt:693124B
	D4 Mushroom	Gal:693408D Qt:693124D
	H8 Shale	Gal:693408H Qt:693124H

Note: Due to printing limitations please use only the Alterna® grout card (F-8241) to select grout. Any grout printed in this brochure is for reference only. See www.armstrongflooring.com/alterna for grout recommendations.

ALTERNA ACOUSTICS DATA

Structure	Installation Method	Ceiling	Underlayment	STC	IIC
6" concrete slab	S-288 Adhesive (Full Spread)	Yes	2400	-	63
6" concrete slab	S-288 Adhesive (Full Spread)	Yes	HMC/Glass	-	51
6" concrete slab	N/A	Yes	Red Flock	-	66
6" concrete slab	S-288 Adhesive (Full Spread) (Two layer glued down)	Yes	S-1840	-	67
6" concrete slab	S-288 Adhesive	Yes	None	63	46
6" concrete slab	S-288 Adhesive (Full Spread)	Yes	None	-	49

STRATAMAX[®]

VINYL SHEET

STRATAMAX GOOD, VALUE PLUS & VALUE VINYL SHEET

- The proprietary StrataMax base layer is made with 70% limestone, providing the ultimate resistance to rips, tears and gouges
- Urethane Plus on GOOD and VALUE PLUS provides superior protection from scratches, scuffs and stains
- Vinyl no-wax wear layer on VALUE is easy to clean and maintain
- True loose-lay installation allows for faster installations and even faster replacements

MADE IN THE USA



Armstrong[®] Vinyl Flooring is manufactured with global and domestic content.



STRATAMAX[®] VALUE PLUS
Ceruse Oak
Wolf Run X4830

PRODUCT STRUCTURE

STRATAMAX GOOD, VALUE PLUS & VALUE VINYL SHEET

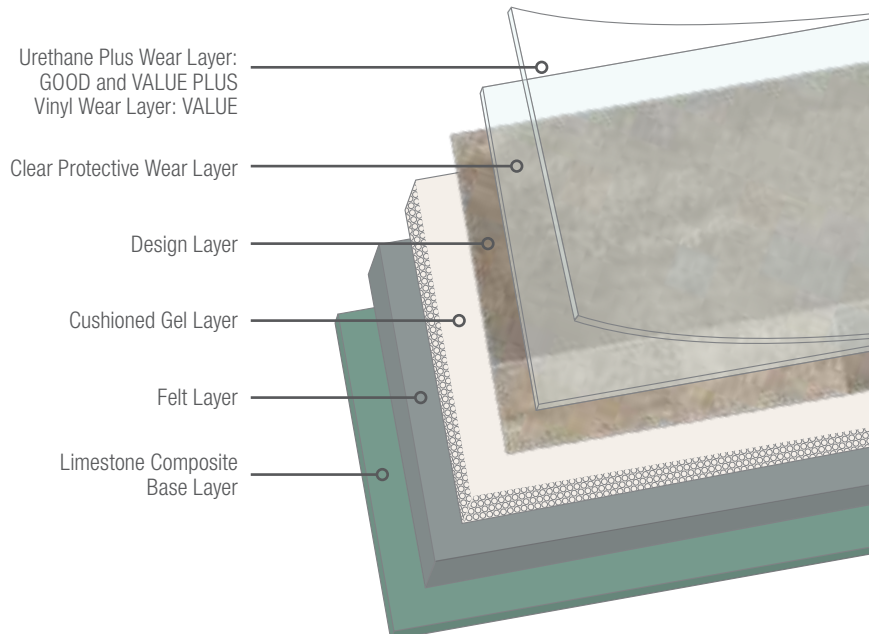

STRATAMAX® GOOD



HARDLAND OAK
Emeline Grey X4467
54" design repeat, 6" random economy match, 6" oak plank pattern



HARDLAND OAK
Olivia Brown X4468
54" design repeat, 6" random economy match, 6" oak plank pattern



HARDLAND OAK
Driftwalk X4466
54" design repeat, 6" random economy match, 6" oak plank pattern



HARDLAND OAK
Oyster Shell X4469
54" design repeat, 6" random economy match, 6" oak plank pattern



HARDLAND OAK
Timber Ridge X4470
54" design repeat, 6" random economy match, 6" oak plank pattern



HARDLAND OAK
Alex Grey X4465
54" design repeat, 6" random economy match, 6" oak plank pattern



BRUSHEDSIDE OAK
Mild Brown X4460
54" design repeat, 6" random economy match, 4", 5" & 6" wire brush oak pattern



BRUSHEDSIDE OAK
Brushed Gray X4461
54" design repeat, 6" random economy match, 4", 5" & 6" wire brush oak pattern



OLD COUNTRY
Mid Natural X4415
54" design repeat, 6" random economy match, wood plank pattern



OLD COUNTRY
Saddle Brown X4416
54" design repeat, 6" random economy match, wood plank pattern



TIMEKEEPER'S CALL
Shore Taupe X4481
54" design repeat, random economy match, 8", 6.5" & 5.5" distressed plank pattern



TIMEKEEPER'S CALL
Dock Gray X4480
54" design repeat, random economy match, 8", 6.5" & 5.5" distressed plank pattern



NEW FOREST
Rustic Mocha X4420
54" design repeat, 6" random economy match, 5-1/4" hickory plank pattern



WOODCREST
Dark Natural X4400
54" design repeat, 4.5" random economy match, distressed plank pattern



VILLA GROVE
Natural Maple X4405
54" design repeat, random economy match, variable width plank pattern



WINSFORD OAK
Gunstock X4417
54" design repeat, 6" random economy match, wood plank pattern



ROCKVALE
Alabaster X4437
54" design repeat, 18" random economy match, 9" travertine stone pattern

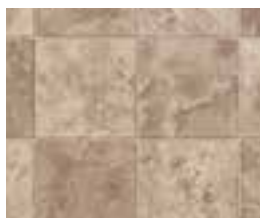

ROCKVALE
Mystic Taupe X4436
54" design repeat, 18" random economy match, 9" travertine stone pattern



ROCKVALE
Soft Sand X4435
54" design repeat, 18" random economy match, 9" travertine stone pattern

SPECIFICATIONS

ROLL SIZE
6' or 12'

OVERALL THICKNESS
65 mils

WEAR LAYER THICKNESS
10 mils

WEAR LAYER
Urethane Plus*

STRUCTURE
Limestone
Encapsulated Felt

LIMITED WARRANTY
Res: 20-year Limited

* Available on select StrataMax Good and StrataMax Value Plus products.

STRATAMAX® VINYL SHEET

STRATAMAX® GOOD



GLEN HAVEN
Earth Tone X4445
27" design repeat, n/a economy match,
9" ceramic pattern



PEMBERTON
Slate Greige X4440
54" design repeat, 9" economy match,
9" slate pattern



PEMBERTON
Brown X4441
54" design repeat, 9" economy match,
9" slate pattern



RIDGEWAY
Classic Tan X4425
24" design repeat, 12" economy match,
12" limestone paver pattern



AMBLESIDE
Beige Blush X4450
54" design repeat, n/a economy match,
overall pattern



BALMORAL
Khaki Brown X4411
24" design repeat, n/a economy match,
12" slate tile pattern



HASTINGS
Light Beige X4410
24" design repeat, n/a economy match,
12" slate tile pattern



PARCHMENT LIVING
Autumn X4475
54" design repeat, 18" economy match,
wenge texture pattern



STONEHAM
Mountain Brown X4430
48 design repeat, 12" economy match,
12" slate paver pattern

STRATAMAX® VALUE PLUS



HARDLAND OAK
Emeline Grey X4720
54" design repeat, 6" random economy
match, 6" oak plank pattern



HARDLAND OAK
Driftwalk X4822
54" design repeat, 6" random economy
match, 6" oak plank pattern



HARDLAND OAK
Oyster Shell X4824
54" design repeat, 6" random economy
match, 6" oak plank pattern

SPECIFICATIONS

ROLL SIZE
6' or 12'

OVERALL THICKNESS
65 mils

WEAR LAYER THICKNESS
10 mils

WEAR LAYER
Urethane Plus*

STRUCTURE
Limestone
Encapsulated Felt

LIMITED WARRANTY
Res: 20-year Limited

* Available on select StrataMax
Good and StrataMax Value
Plus products.

SPECIFICATIONS

ROLL SIZE
6' or 12'

OVERALL THICKNESS
60 mils

WEAR LAYER THICKNESS
10 mils

WEAR LAYER
Urethane Plus*

STRUCTURE
Limestone
Encapsulated Felt

LIMITED WARRANTY
Res: 15-year Limited

* Available on select StrataMax
Good and StrataMax Value
Plus products.

STRATAMAX® VALUE PLUS



HARDLAND OAK
Alex Grey X4820
54" design repeat, 6" random economy match, 6" oak plank pattern



OLD COUNTRY
Mid Natural X4735
54" design repeat, 6" random economy match, wood plank pattern



OLD COUNTRY
Saddle Brown X4740
54" design repeat, 6" random economy match, wood plank pattern



LAKE POINT TIMBERS
Hostler Dust X4773
54" design repeat, 4" random economy match, 4.5" oak plank pattern



LAKE POINT TIMBERS
Scarlet Brown X4772
54" design repeat, 4" random economy match, 4.5" oak plank pattern



LAKE POINT TIMBERS
Western Rise X4770
54" design repeat, 4" random economy match, 4.5" oak plank pattern

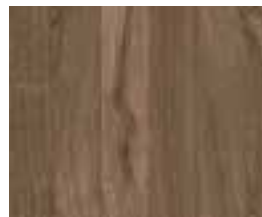

LAKE POINT TIMBERS
Caramel Saddle X4771
54" design repeat, 4" random economy match, 4.5" oak plank pattern



TITAN TIMBERS
Wild Bay X4781
54" design repeat, 6" random economy match, 5-1/8" split oak plank pattern



TITAN TIMBERS
Silver Dapple X4782
54" design repeat, 6" random economy match, 5-1/8" split oak plank pattern



TITAN TIMBERS
Seal Brown X4783
54" design repeat, 6" random economy match, 5-1/8" split oak plank pattern



WAYFARER'S REST
Ashley Hue X4715
54" design repeat, 8" random economy match, 4", 5" & 6" wire brush oak pattern



WAYFARER'S REST
Albritton Brown X4716
54" design repeat, 8" random economy match, 4", 5" & 6" wire brush oak pattern



WAYFARER'S REST
Forcade Forest X4717
54" design repeat, 8" random economy match, 4", 5" & 6" wire brush oak pattern



HEARTHTON HANDSCRAPED
Chromed Risk X4790
54" design repeat, 9" economy match, 4", 5" & 6" handscraped pattern



HEARTHTON HANDSCRAPED
Mahogany Dancer X4791
54" design repeat, 9" economy match, 4", 5" & 6" handscraped pattern



BILLY BANDSAW
Coyote Coat X4786
54" design repeat, 6" random economy match, 5-1/8" split oak plank pattern



BILLY BANDSAW
Burnished Black X4785
54" design repeat, 6" random economy match, 5-1/8" split oak plank pattern



BILLY BANDSAW
Red Sorrel X4787
54" design repeat, 6" random economy match, 5-1/8" split oak plank pattern



DISTRESSED HICKORY
Rustic Mocha X4750
54" design repeat, 6" random economy match, 5-1/4" hickory plank pattern

SPECIFICATIONS

ROLL SIZE
6' or 12'

OVERALL THICKNESS
60 mils

WEAR LAYER THICKNESS
10 mils

WEAR LAYER
Urethane Plus*

STRUCTURE
Limestone
Encapsulated Felt

LIMITED WARRANTY
Res: 15-year Limited

* Available on select StrataMax Good and StrataMax Value Plus products.

STRATAMAX® VINYL SHEET

STRATAMAX® VALUE PLUS



DEEP CREEK TIMBERS
Hearth X4765
54" design repeat, 4" random economy match, variable width plank pattern



DEEP CREEK TIMBERS
Fireside X4766
54" design repeat, 4" random economy match, variable width plank pattern



DEEP CREEK TIMBERS
Dark Mocha X4767
54" design repeat, 4" random economy match, variable width plank pattern



WINDSOR OAK
Gunstock X4815
54" design repeat, 6" random economy match, wood plank pattern



NATURAL PECAN
Summer Tone X4755
54" design repeat, 4" random economy match, 4" plank pattern



WOODCREST
Dark Natural X4745
54" design repeat, 4.5" random economy match, distressed plank pattern



HASTINGS
Light Beige X4730
24" design repeat, n/a economy match, 12" slate tile pattern



HASTINGS
Taupe n' Tan X4775
24" design repeat, n/a economy match, 12" slate tile pattern



CLIFTON EDGE
Draft Hero X4805
48" design repeat, n/a economy match, 12" slate pattern



CLIFTON EDGE
Earthly Strike X4806
48" design repeat, n/a economy match, 12" slate pattern



CLIFTON EDGE
Swell Firework X4807
48" design repeat, n/a economy match, 12" slate pattern



CLIFTON EDGE
Cannondale Chrome X4808
48" design repeat, n/a economy match, 12" slate pattern



CLIFTON EDGE
Auburn Halo X4809
48" design repeat, n/a economy match, 12" slate pattern



TURAN TRAVERTINE
Musty Majestic X4810
54" design repeat, 6" economy match, 6" soft travertine plank pattern



VESSA TRAVERTINE
Malted Emblem X4795
54" design repeat, 18" economy match, 18" x 9" travertine paver pattern



VESSA TRAVERTINE
Coal-Gas Kingdom X4800
54" design repeat, 18" economy match, 18" x 9" travertine paver pattern

SPECIFICATIONS

ROLL SIZE
6' or 12'

OVERALL THICKNESS
60 mils

WEAR LAYER THICKNESS
10 mils

WEAR LAYER
Urethane Plus*

STRUCTURE
Limestone
Encapsulated Felt

LIMITED WARRANTY
Res: 15-year Limited

* Available on select StrataMax Good and StrataMax Value Plus products.

STRATAMAX® VALUE PLUS



VESSA TRAVERTINE
Carbide Charm X4801
54" design repeat, 18" economy match,
18" x 9" travertine paver pattern



VESSA TRAVERTINE
Spent Grindstone X4802
54" design repeat, 18" economy match,
18" x 9" travertine paver pattern



MOUNTAIN SLATE
Beige n' Gray X4760
48" design repeat, 12" economy match,
12" slate paver pattern



CERUSE OAK
Wolf Run X4830
54" design repeat, 6" random economy
match, variable width oak plank pattern



CERUSE OAK
Morris Run X4831
54" design repeat, 6" random economy
match, variable width oak plank pattern



CERUSE OAK
Crossfield Brown X4832
54" design repeat, 6" random economy
match, variable width oak plank pattern



CERUSE OAK
Gold Rush X4833
54" design repeat, 6" random economy
match, variable width oak plank pattern



CERUSE OAK
Porter X4834
54" design repeat, 6" random economy
match, variable width oak plank pattern

STRATAMAX® VALUE



HARDLAND OAK
Emeline Grey X7700
54" design repeat, 6" random economy
match, 6" oak plank pattern



HARDLAND OAK
Olivia Brown X7731
54" design repeat, 6" random economy
match, 6" oak plank pattern



HARDLAND OAK
Driftwalk X7732
54" design repeat, 6" random economy
match, 6" oak plank pattern



HARDLAND OAK
Oyster Shell X7734
54" design repeat, 6" random economy
match, 6" oak plank pattern



HARDLAND OAK
Timber Ridge X7733
54" design repeat, 6" random economy
match, 6" oak plank pattern



HARDLAND OAK
Alex Grey X7730
54" design repeat, 6" random economy
match, 6" oak plank pattern

SPECIFICATIONS

ROLL SIZE
6' or 12'

OVERALL THICKNESS
60 mils

WEAR LAYER THICKNESS
10 mils

WEAR LAYER
Urethane Plus*

STRUCTURE
Limestone
Encapsulated Felt

LIMITED WARRANTY
Res: 15-year Limited

* Available on select StrataMax
Good and StrataMax Value
Plus products.

SPECIFICATIONS

ROLL SIZE
6' or 12'

OVERALL THICKNESS
60 mils

WEAR LAYER THICKNESS
10 mils

WEAR LAYER
Vinyl No-Wax

STRUCTURE
Limestone
Encapsulated Felt

LIMITED WARRANTY
Res: 10-year Limited

STRATAMAX® VINYL SHEET

STRATAMAX® VALUE



DISTRESSED HICKORY
Natural X7715
54" design repeat, 6" random economy match, 5-1/4" hickory plank pattern



DISTRESSED HICKORY
Walnut X7717
54" design repeat, 6" random economy match, 5-1/4" hickory plank pattern



DISTRESSED HICKORY
Rustic Mocha X7716
54" design repeat, 6" random economy match, 5-1/4" hickory plank pattern



BRUSHEDSIDE OAK
Silver Crown X7725
54" design repeat, 6" random economy match, 4", 5" & 6" wire brush oak pattern



HICKORY PLANK
Vintage Timber X7705
54" design repeat, 4" random economy match, 4" hickory plank pattern



WOODCREST
Dark Natural X7710
54" design repeat, 4.5" random economy match, distressed plank pattern



ANCIENT SLATE
Autumn X7586
27" design repeat, 9" random economy match, 9" slate paver pattern



ANCIENT SLATE
Horton Wicker X7585
27" design repeat, 9" random economy match, 9" slate paver pattern



BEACON ROCK
Parchment X7500
48" design repeat, 12" economy match, 12" travertine pattern



CHESWICK
Mesa Gray X7506
27" design repeat, 9" economy match, 9" slate paver pattern



CHESWICK
Sahara Sand X7505
27" design repeat, 9" economy match, 9" slate paver pattern

SPECIFICATIONS

ROLL SIZE
6' or 12'

OVERALL THICKNESS
60 mils

WEAR LAYER THICKNESS
10 mils

WEAR LAYER
Vinyl No-Wax

STRUCTURE
Limestone
Encapsulated Felt

LIMITED WARRANTY
Res: 10-year Limited



STRATAMAX® VALUE



EVENDALE SLATE
Deep Copper Fruit X7566
54" design repeat, 18" economy match,
9" slate plank pattern



GLENVILLE
Crème X7605
18" design repeat, n/a economy match,
9" ceramic paver pattern



MOUNTAIN SLATE
McArthur Mist X7590
48" design repeat, 12" economy match,
12" slate paver pattern



RIDGEFIELD
Coral Sand X7595
24" design repeat, n/a economy match,
12" slate tile pattern



ROCKVALE
Soft Sand X7510
54" design repeat, 18" economy match,
9" travertine stone pattern



BRIDGETON
Parchment X7600
24" design repeat, n/a economy match,
12" ceramic tile pattern

SPECIFICATIONS

ROLL SIZE
6' or 12'

OVERALL THICKNESS
60 mils

WEAR LAYER THICKNESS
10 mils

WEAR LAYER
Vinyl No-Wax

STRUCTURE
Limestone
Encapsulated Felt

LIMITED WARRANTY
Res: 10-year Limited

VINYL SHEET



STRATAMAX™
Woodcrest Dark Natural
X7710 (StrataMax Value)
X4745 (StrataMax Value Plus)
X4400 (StrataMax Good)

FLEXSTEP™

VINYL SHEET

FLEXSTEP GOOD & VALUE PLUS VINYL SHEET

- Fiberglass backed flooring for better underfoot comfort
- Scratch and stain protection with a urethane finish
- Simplified installation with modified loose-lay option or full glue down option

MADE IN THE USA



Armstrong® Vinyl Flooring is manufactured with global and domestic content.



FLEXSTEP® GOOD
Brampton Manor
Maiden's Blush G2719

PRODUCT STRUCTURE FLEXSTEP GOOD & VALUE PLUS VINYL SHEET

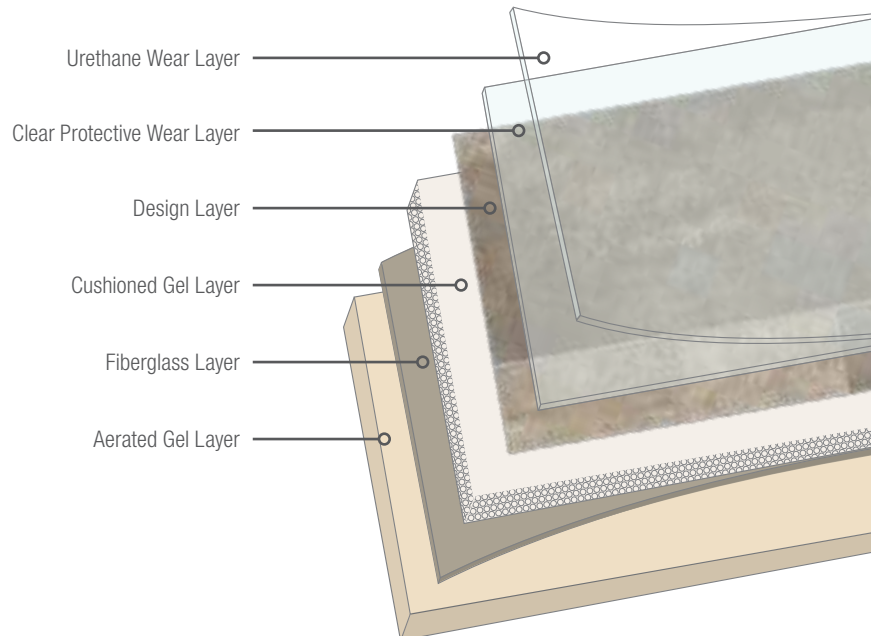

FLEXSTEP™ GOOD



HARDLAND OAK
Emeline Grey G2728
54" design repeat, 6" random economy match, 6" oak plank pattern



HARDLAND OAK
Driftwalk G2725
54" design repeat, 6" random economy match, 6" oak plank pattern



OAK TIMBER
Natural G2706
54" design repeat, 6" random economy match, 4" rustic plank pattern



OAK TIMBER
Cougar Brown G2707
54" design repeat, 6" random economy match, 4" rustic plank pattern



RUSTIC OAK TIMBER
Natural G2704
54" design repeat, 12" random economy match, 8" oak plank pattern



RUSTIC OAK TIMBER
Chestnut Brown G2705
54" design repeat, 12" random economy match, 8" oak plank pattern



WESTHAVEN HICKORY
Acorn G2714
54" design repeat, 6" economy match, 4", 5" & 6" hickory pattern



WESTHAVEN HICKORY
Cinnamon G2713
54" design repeat, 6" economy match, 4", 5" & 6" hickory pattern



WINDSOR WALNUT
Autumn Dusk G2715
54" design repeat, 6" economy match, 5" plank pattern



WINDSOR WALNUT
Peppercorn G2716
54" design repeat, 6" economy match, 5" plank pattern



WOODCREST
Dark Natural G2700
54" design repeat, 4.5" random economy match, distressed plank pattern



BEACON ROCK
Porcelain G2718
48" design repeat, 12" economy match, 12" travertine pattern



BEACON ROCK
Lantern Light G2717
48" design repeat, 12" economy match, 12" travertine pattern



ALAMOSA
Parchment G2710
54" design repeat, 18" economy match, 9" ceramic paver pattern



INDIAN SPRING
Grant Beige G2701
54" design repeat, 9" economy match, 9" slate pattern



INDIAN SPRING
Peanut Shell G2702
54" design repeat, 9" economy match, 9" slate pattern

SPECIFICATIONS

ROLL SIZE
6' or 12'

OVERALL THICKNESS
65 mils

WEAR LAYER THICKNESS
10 mils

WEAR LAYER
Urethane

STRUCTURE
Fiberglass

LIMITED WARRANTY
Res: 15-year Limited

FLEXSTEP™ VINYL SHEET

FLEXSTEP™ GOOD



STONY HILL
Sand G2708
48" design repeat, 12" economy match,
12" slate pattern



STONY HILL
Sienna Brown G2709
48" design repeat, 12" economy match,
12" slate pattern



STONY HILL
Italian Earth G2711
48" design repeat, 12" economy match,
12" slate pattern



BRAMPTON MANOR
Silver Cloud G2721
48" design repeat, 12" economy match,
12" vinecut travertine pattern



BRAMPTON MANOR
Misty Morn G2720
48" design repeat, 12" economy match,
12" vinecut travertine pattern



BRAMPTON MANOR
Maiden's Blush G2719
48" design repeat, 12" economy match,
12" vinecut travertine pattern



PENROSE POINT
Crisp Linen G2722
54" design repeat, 13.5" economy match,
13.5" x 9" staggered travertine pattern



VALLEY BROOK
Dawn G2703
48" design repeat, 12" economy match,
12" slate pattern

SPECIFICATIONS

ROLL SIZE
6' or 12'

OVERALL THICKNESS
65 mils

WEAR LAYER THICKNESS
10 mils

WEAR LAYER
Urethane

STRUCTURE
Fiberglass

LIMITED WARRANTY
Res: 15-year Limited

FLEXSTEP™ VALUE PLUS



HARDLAND OAK
Dunalino Blonde G2495
54" design repeat, 6" random economy
match, 6" oak plank pattern



HARDLAND OAK
Claybank G2496
54" design repeat, 6" random economy
match, 6" oak plank pattern



HARDLAND OAK
Sable Champagne G2497
54" design repeat, 6" random economy
match, 6" oak plank pattern



HARDLAND OAK
Emeline Grey G2470
54" design repeat, 6" random economy
match, 6" oak plank pattern

SPECIFICATIONS

ROLL SIZE
6' or 12'

OVERALL THICKNESS
55 mils

WEAR LAYER THICKNESS
10 mils

WEAR LAYER
Urethane

STRUCTURE
Fiberglass

LIMITED WARRANTY
Res: 10-year Limited

FLEXSTEP™ VALUE PLUS



HARDLAND OAK
Driftwalk G2519
54" design repeat, 6" random economy match, 6" oak plank pattern



HARDLAND OAK
Timber Ridge G2520
54" design repeat, 6" random economy match, 6" oak plank pattern



HARDLAND OAK
Alex Grey G2517
54" design repeat, 6" random economy match, 6" oak plank pattern



COVINGTON OAK
Dovetail G2491
54" design repeat, 6" economy match, 5" oak plank pattern



COVINGTON OAK
Toasted Almond G2490
54" design repeat, 6" economy match, 5" oak plank pattern



COVINGTON OAK
Gunstock G2489
54" design repeat, 6" economy match, 5" oak plank pattern



WARRINGTON WALNUT
Mulberry Grey G2499
54" design repeat, 6" random economy match, 5-1/8" oak plank pattern



WARRINGTON WALNUT
Golden Isabella G2498
54" design repeat, 6" random economy match, 5-1/8" oak plank pattern



WARRINGTON WALNUT
Red Bourbon G2500
54" design repeat, 6" random economy match, 5-1/8" oak plank pattern



ENGLEWOOD
Gunstock G2481
54" design repeat, 4" economy match, oak wood strip pattern



BRUSHEDSIDE OAK
Smoky Perlino G2501
54" design repeat, 6" random economy match, 4", 5" & 6" wire brush oak pattern



BRUSHEDSIDE OAK
Caramel Palomino G2502
54" design repeat, 6" random economy match, 4", 5" & 6" wire brush oak pattern



BRUSHEDSIDE OAK
Silver Crown G2503
54" design repeat, 6" random economy match, 4", 5" & 6" wire brush oak pattern



TITAN TIMBERS
Silver Dapple G2471
54" design repeat, 6" random economy match, 5-1/8" split oak plank pattern



OAK CREEK
Golden Age G2479
48" design repeat, 6" random economy match, 3-1/4" to 4-1/4" oak plank pattern

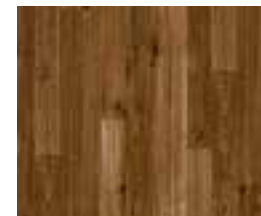

OAK CREEK
Chestnut Brown G2480
48" design repeat, 6" random economy match, 3-1/4" to 4-1/4" oak plank pattern

SPECIFICATIONS

ROLL SIZE
6' or 12'

OVERALL THICKNESS
55 mils

WEAR LAYER THICKNESS
10 mils

WEAR LAYER
Urethane

STRUCTURE
Fiberglass

LIMITED WARRANTY
Res: 10-year Limited

FLEXSTEP™ VINYL SHEET

FLEXSTEP™ VALUE PLUS



CHICKASAW OAK
Autumn Glory G2488
54" design repeat, 6" random economy match, variable width oak plank pattern



CHICKASAW OAK
Cocoa Brown G2487
54" design repeat, 6" random economy match, variable width oak plank pattern



EVENDALE SLATE
Snow Gold G2507
54" design repeat, 18" economy match, 9" slate pattern



EVENDALE SLATE
Deep Copper Fruit G2508
54" design repeat, 18" economy match, 9" slate pattern

SPECIFICATIONS

ROLL SIZE
6' or 12'

OVERALL THICKNESS
55 mils

WEAR LAYER THICKNESS
10 mils

WEAR LAYER
Urethane

STRUCTURE
Fiberglass

LIMITED WARRANTY
Res: 10-year Limited



EVENDALE SLATE
Yeasty Tonic G2509
54" design repeat, 18" economy match, 9" slate pattern



EVENDALE SLATE
American Carbine G2510
54" design repeat, 18" economy match, 9" slate pattern



EVENDALE SLATE
Matchbox Strike G2512
54" design repeat, 18" economy match, 9" slate pattern



SKYE GATE SLATE
White Flaxen G2513
54" design repeat, 6" random economy match, 6" slate plank pattern



SKYE GATE SLATE
Henna 'n' Coal G2514
54" design repeat, 6" random economy match, 6" slate plank pattern



SKYE GATE SLATE
Lava Treacle G2515
54" design repeat, 6" random economy match, 6" slate plank pattern



SKYE GATE SLATE
Old Muscat G2516
54" design repeat, 6" random economy match, 6" slate plank pattern



SARATOGA STONE
Café Crème G2492
48" design repeat, 12" economy match, natural 12" stone pattern



SARATOGA STONE
Antique Bronze G2493
48" design repeat, 12" economy match, natural 12" stone pattern



SARATOGA STONE
Sandstone G2494
48" design repeat, 12" economy match, natural 12" stone pattern



SLATESDALE
Beige G2476
27" design repeat, 9" economy match, 9" paver pattern



SELUR TRAVERTINE
Icing Baron G2506
54" design repeat, 6" economy match, 6" travertine pattern



SELUR TRAVERTINE
Evening Charm G2504
54" design repeat, 6" economy match, 6" travertine pattern



SELUR TRAVERTINE
Barley Star G2505
54" design repeat, 6" economy match, 6" travertine pattern



RIDGEFIELD
Coral Sand G2478
24" design repeat, n/a economy match, 12" slate tile pattern

FLEXSTEP™ VALUE PLUS



ELDORADO
Beige Soiree G2486
54" design repeat, 18" economy match,
9" ceramic paver pattern



ELDORADO
Adobe Brown G2485
54" design repeat, 18" economy match,
9" ceramic paver pattern



VESSA TRAVERTINE
Carbide Charm G2474
54" design repeat, 18" economy match,
18" x 9" travertine paver pattern



VESSA TRAVERTINE
Spent Grindstone G2475
54" design repeat, 18" economy match,
18" x 9" travertine paver pattern

SPECIFICATIONS

ROLL SIZE
6' or 12'

OVERALL THICKNESS
55 mils

WEAR LAYER THICKNESS
10 mils

WEAR LAYER
Urethane

STRUCTURE
Fiberglass

LIMITED WARRANTY
Res: 10-year Limited



CARRIAGE PATH
Oyster White G2483
48" design repeat, 12" economy match,
12" modern limestone pattern



CARRIAGE PATH
Amberglow G2484
48" design repeat, 12" economy match,
12" modern limestone pattern



BEDROCK RIDGE
Brown Sugar G2482
48" design repeat, 12" economy match,
12" x 9" rectangular paver pattern



STONEGATE
Winchester Brown G2477
54" design repeat, 18" economy match,
9" slate paver pattern



FOXFIELD MANOR
Bisque G2527
48" design repeat, 12" economy match,
12" modern limestone pattern

VINYL SHEET



FLEXSTEP™ VALUE PLUS
Skye Gate Slate Lava Treacle G2515

STATION SQUARE™ & INITIATOR™ VINYL SHEET

STATION SQUARE™ VINYL SHEET

- Felt backed flooring for durability
- Easy to care for urethane wear layer
- Full glue down installation option

MADE IN THE USA



Armstrong® Vinyl Flooring is manufactured with global and domestic content.

PRODUCT STRUCTURE STATION SQUARE™ VINYL SHEET

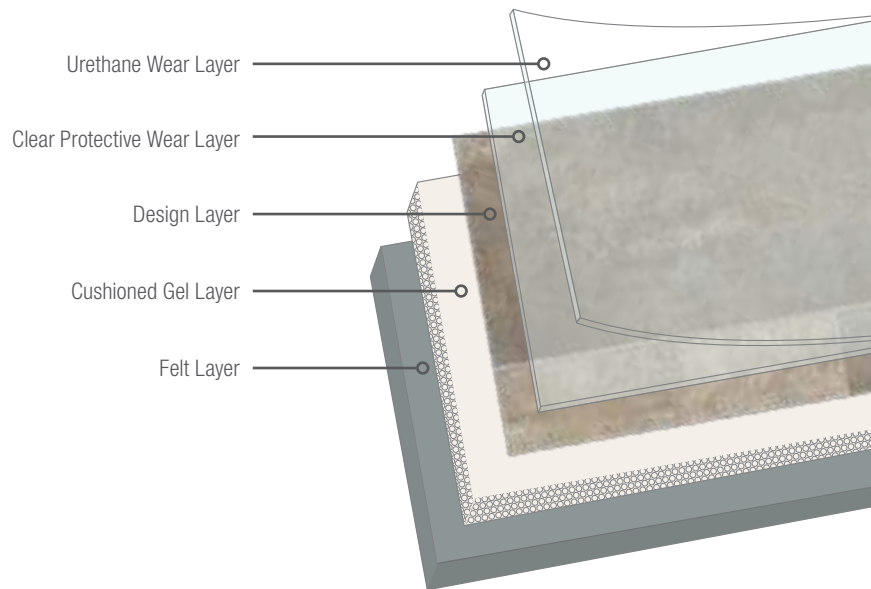

INITIATOR™ VINYL SHEET

- Felt backed flooring for durability
- Vinyl no-wax wear layer is easy to clean and maintain
- Full glue down installation option

MADE IN THE USA



Armstrong® Vinyl Flooring is manufactured with global and domestic content.

PRODUCT STRUCTURE INITIATOR™ VINYL SHEET

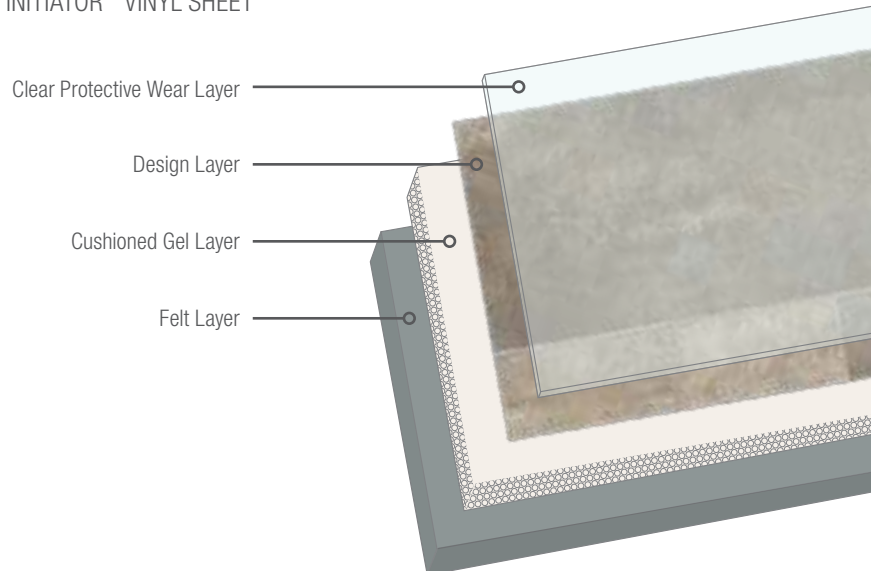

STATION SQUARE™



OLD COUNTRY
Light Natural X2205
54" design repeat, 6" random economy match, wood plank pattern



OLD COUNTRY
Mid Natural X2206
54" design repeat, 6" random economy match, wood plank pattern



OLD COUNTRY
Honey X2207
54" design repeat, 6" random economy match, wood plank pattern



OLD COUNTRY
Saddle Brown X2018
54" design repeat, 6" random economy match, wood plank pattern



TITAN TIMBERS
Silver Dapple X2215
54" design repeat, 6" random economy match, 5-1/8" split oak plank pattern



COVINGTON OAK
Dovetail X2097
54" design repeat, 6" economy match, 5" oak plank pattern



CROSS TIMBERS
Russet X2095
54" design repeat, 12" random economy match, 8" plank pattern



WINDSOR WALNUT
Autumn Dusk X2110
54" design repeat, 6" economy match, 5" plank pattern



WOODCREST
Honey Blond X2002
54" design repeat, 4.5" random economy match, distressed plank pattern



WOODCREST
Dark Natural X2003
54" design repeat, 4.5" random economy match, distressed plank pattern



EVANSTON
Spice X2211
24" design repeat, 12" random economy match, 12" soft limestone paver pattern



EVANSTON
Toffee X2212
24" design repeat, 12" random economy match, 12" soft limestone paver pattern

SPECIFICATIONS

ROLL SIZE
6' or 12'

OVERALL THICKNESS
60 mils

WEAR LAYER THICKNESS
10 mils

WEAR LAYER
Urethane

STRUCTURE
Felt

LIMITED WARRANTY
Res: 10-year Limited

STATION SQUARE™ & INITIATOR™ VINYL SHEET

STATION SQUARE™



HASTINGS
Light Beige X2010
24" design repeat, n/a economy match,
12" slate tile pattern



HASTINGS
Natural X2200
24" design repeat, n/a economy match,
12" slate tile pattern



HASTINGS
Greige X2013
24" design repeat, n/a economy match,
12" slate tile pattern



TURAN TRAVERTINE
Musty Majestic X2171
54" design repeat, 6" economy match,
6" soft travertine plank pattern



PEMBERTON
Polar Bear White X2070
54" design repeat, 9" economy match,
9" slate pattern



PEMBERTON
Grizzly Gray X2072
54" design repeat, 9" economy match,
9" slate pattern



PEMBERTON
Copperhead X2074
54" design repeat, 9" economy match,
9" slate pattern



CLIFTON EDGE
Swell Firework X2197
48" design repeat, n/a economy match,
12" slate pattern



PINNACLE PEAK
Crystal X2055
54" design repeat, 12" economy match,
grouping of 12" slate pattern



PINNACLE PEAK
Burnt Henna X2056
54" design repeat, 12" economy match,
grouping of 12" slate pattern



PINNACLE PEAK
Caviar Toast X2057
54" design repeat, 12" economy match,
grouping of 12" slate pattern



ROCKHAMPTON
Italian Earth X2081
48" design repeat, 12" economy match,
9" slate pattern

SPECIFICATIONS

ROLL SIZE
6' or 12'

OVERALL THICKNESS
60 mils

WEAR LAYER THICKNESS
10 mils

WEAR LAYER
Urethane

STRUCTURE
Felt

LIMITED WARRANTY
Res: 10-year Limited

INITIATOR™



BRAXTON II
Toffee 66231
54" design repeat, 6" random economy match, oak plank pattern



BRAXTON II
Bourbon 66232
54" design repeat, 6" random economy match, oak plank pattern



BRAXTON II
Amber Brown 66233
54" design repeat, 6" random economy match, oak plank pattern



BRAXTON
Gunstock 66122
54" design repeat, 6" random economy match, oak plank pattern



CHICKASAW OAK
Cocoa Brown 66310
54" design repeat, 6" random economy match, variable width oak plank pattern



CROWN POINT
Maize 66280
54" design repeat, 8" random economy match, cherry wood pattern



CROWN POINT
Sable 66281
54" design repeat, 8" random economy match, cherry wood pattern



HICKORY PLANK
Vintage Timber 66247
54" design repeat, 4" random economy match, 4" hickory plank pattern



COTTAGE STONE
After Glow 66253
48" design repeat, 12" economy match, 12" slate pattern



COTTAGE STONE
Fire Walk 66254
48" design repeat, 12" economy match, 12" slate pattern



ANCIENT SLATE
White 66200
27" design repeat, 9" random economy match, 9" slate paver pattern



ANCIENT SLATE
Butterscotch 66202
27" design repeat, 9" random economy match, 9" slate paver pattern



ANCIENT SLATE
Green 66203
27" design repeat, 9" random economy match, 9" slate paver pattern

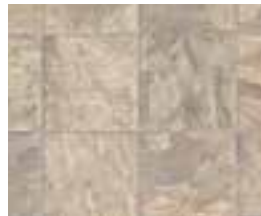

ANCIENT SLATE
Peacock 66205
27" design repeat, 9" random economy match, 9" slate paver pattern



ANCIENT SLATE
Autumn 66204
27" design repeat, 9" random economy match, 9" slate paver pattern



CARLISLE
Talc 66085
24" design repeat, n/a economy match, 12" ceramic pattern



CARLISLE
Greige 66088
24" design repeat, n/a economy match, 12" ceramic pattern



CARLISLE
Mocha 66089
24" design repeat, n/a economy match, 12" ceramic pattern

SPECIFICATIONS

ROLL SIZE
6' or 12'

OVERALL THICKNESS
55 mils

WEAR LAYER THICKNESS
10 mils

WEAR LAYER
Vinyl No-Wax

STRUCTURE
Felt

LIMITED WARRANTY
Res: 7-year Limited

INITIATOR™ VINYL SHEET

INITIATOR™



DARIEN
Almond 66155
24" design repeat, n/a economy match,
12" ceramic tile pattern



DARIEN
Greige 66156
24" design repeat, n/a economy match,
12" ceramic tile pattern



DARIEN
Taupe Blush 66159
24" design repeat, n/a economy match,
12" ceramic tile pattern



DARIEN
Copper 66158
24" design repeat, n/a economy match,
12" ceramic tile pattern



EVENDALE SLATE
Snow Gold 66355
54" design repeat, 18" economy match,
9" slate pattern



EVENDALE SLATE
Deep Copper Fruit 66356
54" design repeat, 18" economy match,
9" slate pattern



EVENDALE SLATE
American Carbine 66358
54" design repeat, 18" economy match,
9" slate pattern



EVENDALE SLATE
Matchbox Strike 66360
54" design repeat, 18" economy match,
9" slate pattern



GLENVILLE
Crème 66180
18" design repeat, n/a economy match,
9" ceramic paver pattern



GLENVILLE
Harvest Biege 66190
18" design repeat, n/a economy match,
9" ceramic paver pattern



GLENVILLE
Mesa Tan 66182
18" design repeat, n/a economy match,
9" ceramic paver pattern

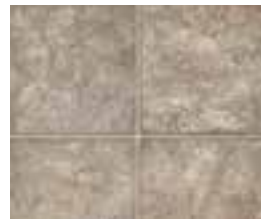

GLENVILLE
Sandy Taupe 66181
18" design repeat, n/a economy match,
9" ceramic paver pattern



BRIDGETON
Parchment 66175
24" design repeat, n/a economy match,
12" ceramic tile pattern



BRIDGETON
Chamois 66177
24" design repeat, n/a economy match,
12" ceramic tile pattern



BRIDGETON
Cinnamon 66178
24" design repeat, n/a economy match,
12" ceramic tile pattern



ELDORADO
Beige Soiree 66272
54" design repeat, 18" economy match,
9" ceramic paver pattern



ELDORADO
Adobe Brown 66270
54" design repeat, 18" economy match,
9" ceramic paver pattern



HUNTLEY ROAD
Sandstone 66235
18" design repeat, n/a economy match,
6" stone paver pattern



HUNTLEY ROAD
Castle Sand 66238
18" design repeat, n/a economy match,
6" stone paver pattern



HUNTLEY ROAD
Earthtone 66240
18" design repeat, n/a economy match,
6" stone paver pattern

SPECIFICATIONS

ROLL SIZE
6' or 12'

OVERALL THICKNESS
55 mils

WEAR LAYER THICKNESS
10 mils

WEAR LAYER
Vinyl No-Wax

STRUCTURE
Felt

LIMITED WARRANTY
Res: 7-year Limited

INITIATOR™



LAKESIDE
Natural Beige 66082
18" design repeat, n/a economy match,
6" paver pattern



SARATOGA STONE
Café Crème 66290
48" design repeat, 12" economy match,
natural 12" stone pattern



SARATOGA STONE
Antique Bronze 66291
48" design repeat, 12" economy
match, natural 12" stone pattern



SELUR TRAVERTINE
Icing Baron 66348
54" design repeat, 6" economy match,
6" travertine pattern



SCOTSGROVE MANOR
Almond 66301
48" design repeat, 12" economy match,
12" modern limestone pattern



TEMPLETON
Light Birch 66146
18" design repeat, n/a economy match,
9" stone pattern



SKY GATE SLATE
White Flaxen 66365
54" design repeat, 6" economy match,
6" slate plank pattern

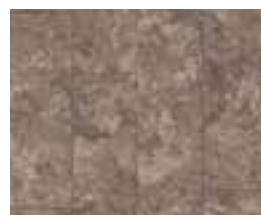

SKY GATE SLATE
Old Muscat 66369
54" design repeat, 6" economy match,
6" slate plank pattern

SPECIFICATIONS

ROLL SIZE
6' or 12'

OVERALL THICKNESS
55 mils

WEAR LAYER THICKNESS
10 mils

WEAR LAYER
Vinyl No-Wax

STRUCTURE
Felt

LIMITED WARRANTY
Res: 7-year Limited

VINYL SHEET



INITIATOR™
Chickasaw Oak Warm Caramel 66311

VINYL SHEET QUICK REFERENCE GUIDE

ENCAPSULATED FELT				
Collection	Gauge/ Wear Layer	Durability & Performance	Installation	Warranty
STRATAMAX®	65 mils/ 10 mils	Urethane Plus*	Loose Lay or Glue Down	20-Year Limited Residential
STRATAMAX®	60 mils/ 10 mils	Urethane Plus*	Loose Lay or Glue Down	15-Year Limited Residential
STRATAMAX®	60 mils/ 10 mils	Vinyl No-Wax	Loose Lay or Glue Down	10-Year Limited Residential

FIBERGLASS				
Collection	Gauge/ Wear Layer	Durability & Performance	Installation	Warranty
FLEXSTEP™	65 mils/ 10 mils	Urethane	Loose Lay or Glue Down	15-Year Limited Residential
FLEXSTEP™	55 mils/ 10 mils	Urethane	Loose Lay or Glue Down	10-Year Limited Residential

FELT				
Collection	Gauge/ Wear Layer	Wear Layer	Installation	Warranty
STATION SQUARE™	60 mils/ 10 mils	Urethane	Glue Down	10-Year Limited Residential
INITIATOR™	55 mils/ 10 mils	Vinyl No-Wax	Glue Down	7-Year Limited Residential

*Available on select StrataMax Good and StrataMax Value Plus products.

GOOD
VALUE PLUS
VALUE

GOOD
VALUE PLUS

QUIET COMFORT™ UNDERLAYMENT OPTIONS

	S-1840 LVT, Rigid Core, & Engineered Tile	S-1841 LVT & Engineered Tile
Sound Barrier	••••	•••
Moisture Barrier	•••	•••••
Ease of Install	••	•••••



Armstrong Flooring provides many options of underlayments that are designed with your environment, flooring product type and installation challenges in mind. They are easy to work with, require less subfloor preparation and enhance the overall floor performance.

	BETTER			BEST
	S-1841 Quiet Comfort™ Floating Underlayment			S-1840 Quiet Comfort™ Floating Underlayment
	Standard 100 sq. ft. roll FP01841101	Standard 350 sq. ft. roll FPX2411205	Jumbo ~1,600 sq. ft. roll FPX2410205	300 sq. ft. roll FP1840101
Key Features & Benefits	Reduces subfloor prep and simplifies installation. Moisture barrier with no RH limit and resists mold and mildew. Reduces through-the-floor and in-room footfall noise.			Built-in moisture barrier and adapts to subfloor irregularities.
Construction	HMC Saturated Polyester			Polypropylene Foam
Gauge	0.02" (0.5 mm)			0.039" (1 mm)
STC/IIC*	62/57			62/64
Color	Gray			Black
Dimensions (WxL)	6' x 16.7'	6' x 58.3'	6' x 225'	6' x 50'
Suitable for products	For use with LVT & Engineered Tile			For use with LVT, Rigid Core, & Engineered Tile

These products are not subject to the newly imposed tariffs.

*The ASTM tests for determining STC and IIC values do not specify a standard floor-ceiling structure for conducting the tests. The floor-ceiling structure used for the tests should be considered when comparing STC and IIC values of competitive products. Refer to FloorExpert.com for more information.



AMERICAN PERSONALITY™ 12
Crafted Oak
Essential Beige K1010

UNDERLAYMENT OPTIONS

ADHESIVES AND FLOOR CARE

		Armstrong® Adhesive #	Common Name	Benefit	FloorScore® certification
ALTRNA	Grout	S-693	FlexStrong™ Grout	<ul style="list-style-type: none"> No sealing required – saves you time and money Stain-resistant Can grout right away – no need to wait 	
	Adhesive	S-288	Premium Flooring Adhesive	<ul style="list-style-type: none"> Creates a strong, permanent bond to your floor Easy to trowel 	✓ +C2C Gold
LVT	High-Moisture	S-310	Roll Strong™; roller applied adhesive	<ul style="list-style-type: none"> One coat, rolled on application Easier, less time consuming installation Short open time Suitable for immediate traffic. 	✓
	High-Moisture	S-599	Commercial Sheet and Residential LVT Adhesive	<ul style="list-style-type: none"> High spread rate Strong, early grab Short open time Multi-functional 	✓ +C2C Gold
	High-Moisture	S-288	Premium Flooring Adhesive	<ul style="list-style-type: none"> Creates a strong, permanent bond to your floor Easy to trowel 	✓ +C2C Gold
	Releasable	S-289	Releasable & Permanent Adhesive	<ul style="list-style-type: none"> Easy to replace the floor once installed Allows for easy repairs 	✓
FELT BACKED SHEET	Premium	S-235	Sheet Flooring Premium Adhesive	<ul style="list-style-type: none"> Short open time Fast initial grab Additional bond strength Installable on wider range of subfloors Commercial grade 	✓
	Standard	S-254	Residential Sheet Flooring Adhesive	<ul style="list-style-type: none"> Short open time Fast initial grab 	✓
FIBERGLASS BACKED SHEET	Premium	S-288	Premium Flooring Adhesive	<ul style="list-style-type: none"> Creates a strong permanent bond to your floor Floors can be installed wet or dry to touch Easy to trowel 	✓ +C2C Gold
	Releasable	S-289	Releasable & Permanent Adhesive	<ul style="list-style-type: none"> Releasable and permanent adhesive Allows for easy repairs Easy to replace the floor once installed 	✓
VCT	High-Moisture	S-515	Floor Tile Adhesive	<ul style="list-style-type: none"> High moisture guarantee Dries clear to easily see chalk lines Longer working time 	✓
	Premium	S-750	Premium Floor Tile Adhesive	<ul style="list-style-type: none"> Can be used as a primer Recommended for tile-on installations 	✓
	Standard	S-700	Thin Spread Floor Tile Adhesive	<ul style="list-style-type: none"> Black asphalt adhesive Covers 350-400 sf/gallon 	✓
SPECIALTY	Spray Adhesive	Flip®	Flip® Spray Adhesive	<ul style="list-style-type: none"> Quick install with one step application High-moisture guarantee No waiting to return to space For use with LVT, VCT and Commercial Sheet 	✓ +CS2 Gold
	Seams	S-761**	Seam Adhesive for Sheet Floors	<ul style="list-style-type: none"> Quick and easy seaming method Excellent seam integrity Can install in 15 minutes 	
		S-500	Seam Coater	<ul style="list-style-type: none"> Quick and easy coated method Covers 50-60 linear feet No special tools For use with residential felt-backed products 	



S-289 Releaseable & Permanent Adhesive



S-693 FlexStrong™ Grout with pre-mixed sanded acrylic

*When Summit trowel is used and when used in accordance with Armstrong installation instructions.
**Not for use with residential felt-backed products or Stratamax Value/Plus

RESILIENT FLOOR CARE PRODUCTS

Armstrong® Multi-Surface Floor Cleaner Spray and Refill—Fresh linen scent and ammonia-free formula.

- Armstrong Multi-Surface Floor Cleaner Spray (32 oz.)—Ready to use, leaves no streaks or residue
- Armstrong Multi-Surface Floor Cleaner Refill (64 oz.)—Use to refill spray mops and spray bottles

Also available:

- Armstrong Multi-Surface Floor Cleaner Concentrate (32 oz.)—Sponge mop, no rinse/no residue, makes 16 gallons
- Armstrong Multi-Surface Floor Finish (27 oz.)—Shines, protects and restores



For additional information about specific floor care products and where to purchase, please visit www.armstrongflooring.com/floorcare



AMERICAN PERSONALITY™ 12
Richland Walnut
Indigo Blush K1020

Inspiring Great Spaces®

Armstrong Flooring has all your floors covered:

Luxury Vinyl Tile • Engineered Tile • Vinyl Sheet • Rigid Core

For more than a century, Armstrong Flooring has been known and trusted the world over for consistent quality, innovative design and satisfied customers.



Armstrong Flooring is proud to be a national sponsor of Homes for Our Troops, a non-profit organization dedicated to helping wounded veterans achieve freedom and independence by providing newly constructed, specially adapted homes at no cost. For more information, visit www.hfotusa.org.



Armstrong and the Armstrong Logo are trademarks of AWI Licensing LLC. Unless otherwise indicated, all other trademarks are owned by AFI Licensing LLC.

FloorScore™ is a trademark of the Resilient Floor Covering Institute. Hanley Wood® is a registered trademark of Hanley-Wood, LLC.

NOTE: Due to printing limitations, colors pictured cannot be guaranteed to match actual flooring material.

© 2019 AFI Licensing LLC

F-8564-1218

www.armstrongflooring.com/builderpm

QUESTIONS? Please see your local Armstrong Flooring representative.

To View All Products:
www.armstrongflooring.com

For Technical and Installation Information:
www.floorexpert.com



Shown on cover:
AMERICAN PERSONALITY™ 12
Lakehouse Hickory
Greige Twist K1000